

प्रश्न बैंक

ENGLISH

कक्षा

6

7

8

के लिए



राज्य शैक्षिक अनुसंधान और प्रशिक्षण परिषद्
शंकर नगर, रायपुर छत्तीसगढ़

प्रकाशन वर्ष 2015-16

मार्गदर्शन एवं सहयोग
संजय कुमार ओझा (संचालक) एस.सी.ई.आर.टी.

कार्यक्रम सवन्वयक
श्रीमती विद्या डांगे एस.सी.ई.आर.टी., रायपुर

विषय विशेषज्ञ
श्रीमती एस.एन. अली, सुश्री शिशिर कना भट्टाचार्य

लेखक
श्रीमती केका साहू, श्रीमती रंजना ध्रुव, शबाना आजमी, सुश्री पारूल कोन्हेर,
ओमप्रकाश दीवान, मनीष पाण्डे, लक्ष्मण माणिकपुरी

टंकण एवं लेआउट डिजाईनिंग
चरण साहू, संजय साहू, अमन शर्मा, तरुण शर्मा

प्रकाशक
राज्य शैक्षिक अनुसंधान और प्रशिक्षण परिषद्, रायपुर

आमुख

प्रश्न बैंक प्रश्नों का विशाल संग्रह है जो पाठ्य पुस्तक में दिए गए प्रश्नों के अतिरिक्त है। प्रश्न बैंक के प्रश्न जानकारी, अनुप्रयोग, कौशल एवं समझ आधारित है। प्रश्न बैंक का मुख्य उद्देश्य प्रश्नों के माध्यम से पाठ्यचर्या 2005 में वर्णित सिद्धांतों के अनुसार शिक्षा के लक्ष्यों को प्राप्त करना है। प्रश्न बैंक के प्रश्नों का उपयोग परीक्षा के लिए प्रश्न पत्र बनाने के अलावा कक्षा अध्यापन की प्रक्रिया में अपेक्षित कौशलों के विकास को जाँचने के लिए भी कर सकते हैं। इन प्रश्नों के माध्यम से बच्चों में स्वयं करके सीखने, अपने परिवेश को समझने, तर्क करने, चिंतन करने, अपने अनुभवों को अभिव्यक्त करने आदि कौशलों का विकास हो सकेगा। प्रश्न बैंक में दिए गए प्रदत्त कार्य, सर्वे कार्य, प्रोजेक्ट कार्य, पोर्टफोलियों के माध्यम से बच्चों में सक्रियता, सहभागिता, समुदाय से जुड़ाव तथा पाठ्यपुस्तक में वर्णित अवधारणाओं को और अधिक पुष्ट करने में मदद मिलेगी।

बच्चों को रटत प्रणाली से दूर करने, विद्यालयीन ज्ञान को अपने दैनिक जीवन में उपयोग करने तथा भाषायी कौशलों के विकास हेतु प्रश्न बैंक में खुले प्रश्नों का समावेश किया गया है अर्थात् दिए गए प्रश्नों का उत्तर प्रत्येक विद्यार्थी द्वारा अपने-अपने संदर्भों में देने के कारण प्रश्नों के उत्तर पृथक-पृथक हो सकते हैं। अतः उत्तरों की जांच में शिक्षक की भूमिका अत्यन्त महत्वपूर्ण होगी, अतः शिक्षकों से यह अपेक्षा की जाती है कि वे एक ही प्रारूप में बच्चों से प्रश्नों के उत्तरों की अपेक्षा न करते हुए उनके द्वारा लिखे गए प्रश्नों की जांच संदर्भों के आधार पर करें। बच्चों को उत्तर ढूँढने के लिए पर्याप्त समय दे। उनके द्वारा किए गए कार्यों को प्रोत्साहित करें, प्रश्नों को हल करने में उनकी मदद करें तथा उनके द्वारा की गई त्रुटियों में सुधार करें।

आशा है यह प्रश्न बैंक आपके लिए उपयोगी होगा। प्रश्न बैंक संबंधी कोई सुझाव हो तो आप हमें अवश्य अवगत करावें।

विषय - सूची

class-6 English-Reader

S.No.	Lessons	Page No.
1.	Conversation	1
2.	Mr. Sun Goes on a Holiday	4
3.	Pretending	9
4.	A Masai Home	12
5.	Alice in Wonderland	16
6.	In th Heart of a Seed	19
7.	Jolly Kittens	21
8.	The Hare on the Moon	23
9.	Running and Shouting	26
10.	Jagatu - The Gardener	28
11.	Left in Charge	31
12.	Who has Seen the Wind ?	33
13.	Gopal Bhand and Mahagyani	35
14.	Puppy and I	39
15.	A Nickel's Worth of Fun	42
16.	Women for Trees	45
17.	Little Drops of Water	49

विषय - सूची

class-7 English-Reader

S.No.	Lessons	Page No.
1.	Hobble-Bobble	53
2.	The Missing Whistle	57
3.	Hand Care	62
4.	Hard to Believe	64
5.	Alice in Wonderland-II	67
6.	Unity Is Strength	70
7.	Jimmy Jet and His TV Set	73
8.	A Serious Talk	76
9.	Have a Cup of Nice Tea	79
10.	Our Little River	86
11.	Grandchildren by Surprise	89
12.	The Chinese-Our Neighbour	93
13.	Only God can Make a Tree	97
14.	The Angel of Peace	100
15.	The Glorious Whitewasher	104
16.	Half-way Down	107
17.	Making Best Out of Waste, Her Forte	109
18.	Dear Diary.....	114
19.	From Tomorrow on	118
20.	Unfriendly Nature	120
21.	The Great Sculler	124

विषय - सूची

class-8 English-Reader

S.No.	Lessons	Page No.
1.	Water's for...	129
2.	The Shoemaker and the Elves	134
3.	Measure for Measure	137
4.	The Tree that Never Stopped Giving	140
5.	Alice in Wonderland	143
6.	From a Railway Carriage	145
7.	Everyday Heroes	148
8.	At School	150
9.	Beats in Memoir	152
10.	A Place Fit for God's to Marry	154
11.	Sympathy	156
12.	Children ask Kalam	158
13.	Syani	160
14.	Craze	161
15.	The Bird-man of India	163
16.	The Mountain and the Squirrel	165
17.	Nothing but the Target	167
18.	Dancing On	169
19.	Dear Daddy-Long-Legs	172
20.	Fog	174
21.	Flavours of Thailand	177
22.	The Photograph	182
23.	Where the Mind is Without Fear	184

प्रश्न बैंक
अंग्रेजी

कक्षा - 6

Lesson - 1

Conversation

Q.1 Fill up the blanks with the given words (thin, busy, door, floor, you)

- a) Here is the
- b) You have to be.....
- c) I'm all day
- d) under the.....
- e) can't get in

Q.2 Say 'True' or 'false'

- 1) Mousie is a mouse
- 2) The cat is thin
- 3) The mousie is busy
- 4) The rat is fat
- 5) The mouse lives in jungle

Q.3 Rearrange the letters and write the correct spelling (दिये गये अक्षरों को सही क्रम में जमाकर सही स्पेलिंग लिखिये)

- | | | | |
|--------------|--------------|--------------|------------|
| (i) mousei | (ii) Doro | (iii) Foolr | (iv) Tihn |
| (v) ady | (vi) ocme | (vii) ohusie | (viii) asy |
| (ix) dya | (x) orrys | (xi) ubsy | (xii) aisd |
| (xiii) nuder | (xiv) heer | (xv) lttile | (xvi) your |
| (xvii) bsuy | (xviii) have | (xix) yuo | (xx) out |

Q.4 Write the meanings in Hindi

Mousie, door, floor, thin, busy,

Q.5 Match the rhyming words

- | | | |
|--------|---|--------|
| Mousie | - | cat |
| door | - | thin |
| in | - | floor |
| sya | - | housie |
| rat | - | day |

Q.6 Answer the following Question

Q. (1) Who is mousie?

Q. (2) Where is the door?

Q. (3) Complete the poem

- (i) Mousie
- (ii) Where is your wee housie.
- (iii) Here is the
- (iv) Cinder the

Q. (4) Draw the picture of mousie?

Q. (5) Draw the picture of the rat?

Q. (6) Fill in the missing letters

... nder, f...oor, mou...ie, bu...y, s...rry,

Q.7 Write the naming words (noun) given in the poem

“mousie, mousie

Where is your little wee housie?”

“Here is the door

Under the floor,”

Said mousie, mousie

Q.8 Write the following lines of the poem neatly and correctly as given

“ *mousie, mousie,*

May I come into your housie?”

“you can’t get in,

You have to be thin,”

Said mousie, mousie.

Q.9 What will you say in the following situations?

a) When you want to come in to the class.

b) When you want to go out of your class.

Long answers

Q.10 Did the mousie invite the cat to come to his house?

Q.11 Why did the mouse not allow the cat to enter the house?

Q.12 Why did the mouse not like to come out of his house?

Q.13 Write 5 lines of the poem “Conversation”

Q.14 Give 4 rhyming words of the given words

a) door

b) thin

c) say

Q.15 Name 5 things you can see in the picture of Mousie's house

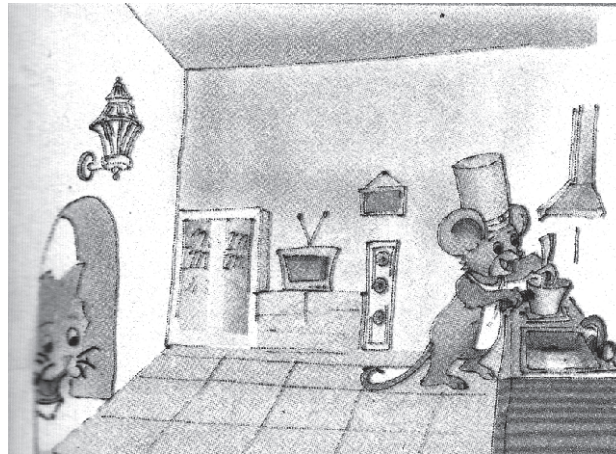

Q.16 Given short forms

Ex. (1) isn't = Is not (2) aren't = _____ (3) can't = _____
 (4) wasn't = _____ (5) I'm = _____ (6) wasn't = _____

Q.17 Write the full forms of the given contracted forms

(1) Isn't - is not (2) Aren't -
 (3) Can't - (4) Won't -
 (5) I'm - (6) Wasn't -

Q.18 Match the contracted form to the full form

1) wasn't - was not
 2) I'm - will not
 3) won't - can not
 4) can't - I am
 5) Aren't - Is not
 6) Isn't - Are not

Q.19 Who said

1) Where is the door. _____
 2) May I come in to your housie? _____
 3) I'm busy all day _____
 4) Won't you come out of your housie? _____
 5) You have to be thin _____

Lesson - 2

The Sun Goes On a Holiday

Q.1 Answer the following question in one word only

- 1) Who goes on a holiday?
- 2) What covered the earth?
- 3) Who was chasing his friend?
- 4) Who searched for the sun?
- 5) Who peeped out of her nest?
- 6) Who got stuck up the hill?
- 7) Who went back to its hive?
- 8) Who suddenly disappeared from the sky?
- 9) Who felt sorry?
- 10) Who stopped working?

Q.2 Write the meanings in Hindi

Sun, holiday, disappeared, squirrel, chasing, earth, sky, plant, flowers, bee, nest, bird, honey, whisper, bloom, live, wind, hill, window, rise, abode, quite, lifeless, sad, work, river, happy

Q.3 Fill up the blanks with the correct word given in bracket

- 1) The goes on a holiday (*moon, sun*)
- 2) The sun took a holiday on (*Sunday, Monday*)
- 3) A was chasing his friend. (*dog, squirrel*)
- 4) peeped out of her nest. (*mother bird, bee*)
- 5) A little plant searched for the (*star, sun*)
- 6) The bee could not find any (*honey, money*)
- 7) The Got stuck up the hill. (*rain, wind*)
- 8) Men, women and children stopped (*working, running*)
- 9) The flowed joyfully. (*pond, river*)
- 10) The seemed lifeless. (*earth, moon*)

Q.4 Match the following

- | | | |
|---------|---|--------|
| 1) Sun | - | hive |
| 2) Bird | - | kennel |
| 3) Bee | - | abode |
| 4) Men | - | nest |
| 5) Dog | - | home |

Q.5 Match the opposite words

- | | | | | | |
|-----------|---|-------|-----------|---|--------|
| (a) happy | - | close | (b) out | - | up |
| high | - | go | rise | - | appear |
| open | - | end | disappear | - | set |
| start | - | low | kind | - | up |
| come | - | sad | down | - | cruel |

Q.6 Rearrange the letters

- | | | | | | |
|----------|---|-------|-----------|---|-------|
| 1) nus | - | | 2) syk | - | |
| 3) yars | - | | 4) feirnd | - | |
| 5) earth | - | | 6) panlt | - | |
| 7) brid | - | | 8) hneoy | - | |
| 9) wnid | - | | 10) hlil | - | |

Q.7 State 'True' or 'False'

- | | |
|--|-------|
| 1) The moon goes on a holiday. | |
| 2) A squirrel was chasing its friend. | |
| 3) A little plant searched for the food. | |
| 4) The stillness on the earth shocked the sun. | |
| 5) The birds got stuck up the hill. | |
| 6) The sun felt sorry. | |
| 7) Everyone enjoys a holiday. | |
| 8) Darkness covered the sun. | |
| 9) The bee couldn't find any honey. | |
| 10) Children peeped out of her nest. | |

Q.8 Match the following statements

- | | | |
|-----------------------|----|------------------------|
| 1. Little plant | -- | peeped out of her nest |
| 2. Flowers and leaves | -- | stopped working |
| 3. Trees | -- | searched for the sun |

- 4. Mother bird -- bent low to the ground
- 5. Bee missed -- the sun
- 6. Men, women & children -- couldn't find any honey

Q.9 Draw the picture of any 4 and color them

- (1) Sun (2) Squirrel (3) Bee (4) Flower
- (5) Bird (6) Tree (7) House

Q.10 Give the opposite words

here, high, take, down, gain, come, happy, out, all, rise

Q.11 Give the words used in the story "The sun goes on a Holiday" for home

- 1) Abode 2) 3)

Q.12 What did the sun feel when he looked down?

- 1) shocked 2) 3)

Q.13 Where do the following live?

Ex. Where do the children - home

- 1) Bee - 2) Bird -
- 3) Cow - 4) Lion -
- 5) Horse - 6) Dog -
- 7) Fish -

Q.15 Complete the word web with the words related to the word "Home"

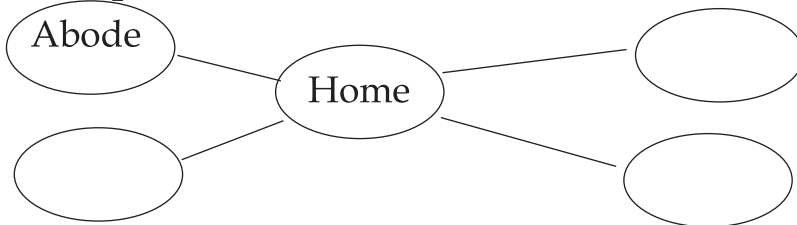

Q.16 Make new words by adding 'ness'

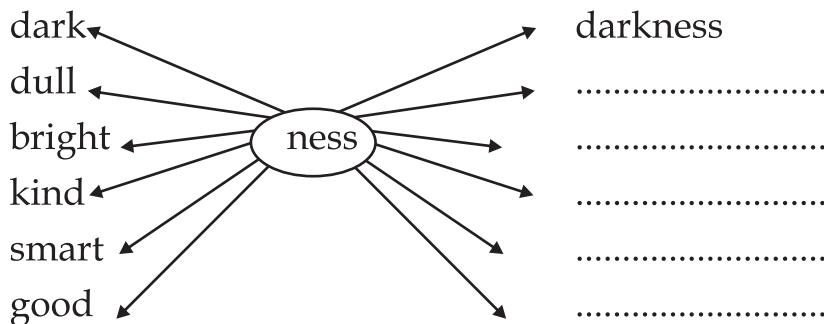

Q.17 When the sun took a holiday what did the following do? Complete the table

Eg.	Little plant	Searched for the sun
1.	Flowers and leaves	
2.	Trees	
3.	Mother Bird	
4.	Bee	
5.	Men, women & children	

Q.18 Dictation

10 words to be dictated by the teacher from the lesson.

Q.19 Complete the paragraph with the given words

(holiday, earth, Sunday, disappeared, darkness)

Everyone enjoys a so, one fine The sun also look a holiday. It suddenly from the sky. covered the

Q.20 What come 'before' and 'after'?

- 1) Sunday 2) Tuesday
 3) Monday 4) Thursday
 5) Wednesday

Q.21 Pick out the opposite words of the given words from the puzzle

- 1) come
 2) dark
 3) out
 4) rise
 5) start

K	Z	G	O	U
L	I	G	H	T
P	K	I	N	B
W	S	E	T	Z
O	D	E	N	D

Assignment:-+

Q.1 Find the words in the puzzle with on the help of the given clues?

- 1) Who goes on a holiday?
 2) The darkness covered the..... ?
 3) Who searched for the sun?
 4) got stuck up the hill
 5) Bees and started singing

E	A	R	T	Z
T	W	I	N	D
P	L	A	N	T
Y	B	I	R	D
Z	O	S	U	N

Q.2 Where do they live? Find out from the puzzle

- 1) Bird
- 2) Bee
- 3) Man
- 4) Cow
- 5) Fish

H	I	V	E	Z
Y	S	H	E	D
W	A	T	E	R
X	N	E	S	T
H	O	M	E	Q



Lesson - 3

Pretending

Q.1 Fill up the blanks

- 1) Its to be this. (fun/bun)
- 2) Its fun to be (bat/that)
- 3) To like a lamb. (leap/sheep)
- 4) To climb like a (hat/cat)
- 5) To like a frog. (hop/shop)

Q.2 Match the following

Example: Lamb - swim

- 1) Fish - hop
- 2) Frog - trot
- 3) Cat - jump
- 4) Horse - climb
- 5) Dog - leap

Q.3 Write the meanings in Hindi

Example: lamb - मेमना

- | | |
|------------|-----------|
| 1) cat - | 2) frog - |
| 3) fish - | 4) dog - |
| 5) horse - | |

Q.4 Fill in the missing letter

- | | | | | |
|-------------|-------------|--------------|-------------|--------------|
| 1) l ... ap | 2) fi ... h | 3) h ... rse | 4) d ... g | 5) ... at |
| 6) la ... b | 7) f ... n | 8) fr ... g | 9) ... limb | 10) j ... mp |

Q.5 State 'True' or 'False'

- | | |
|----------------------|-------------------|
| 1) Cat climbs | 2) Lamb swim..... |
| 3) Horse trots | 4) Dog hops |
| 5) Fish jumps | |

Q.6 Rearrange the letter to make meaningful word.

- | | |
|------------------|-----------------|
| 1) dgo = | 2) lamb = |
| 3) hsore = | 4) forg = |
| 5) fish = | |

Q.7 Draw the picture of the following

- 1) cat 2) dig 3) fish 4) horse 5) frog

Q.8 Complete the word web

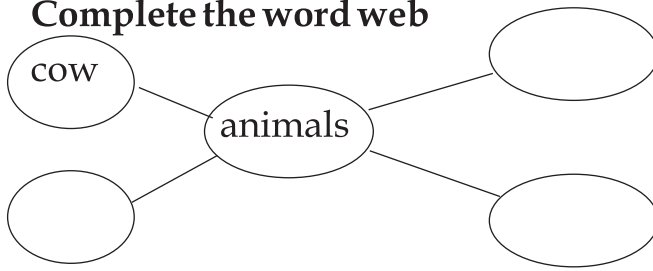

Q.9 Write 4 lines of the poem “Pretending”

Q.10 Add “ing” to the following words

- Example: Pretend+ing = pretending
- 1) climb + =
- 2) jump + =
- 3) copy + =
- 4) work + =
- 5) miss + =

Q.11 Dictation

(Teacher will dictate 5 words from the poem)

Q.12 Write the names of 5 animals?

Q.13 Pick out the names of the birds that can fly.

Cat, sparrow, pigeon, elephant, crow, cow, eagle, rabbit, parrot, tiger

Q.14 Pick out the names of the creatures that can swim

fish, buffalo, crocodile, snake, bear, tortoise, monkey, frog, goat, pig

Q.15 Separate the animals who “can swim” and who “can fly” in their column

Sparrow, fish, pigeon, crocodile, crow, snake, eagle, parrot, tortoise, frog

	Can swim		Can fly
1		1	
2		2	
3		3	
4		4	
5		5	

Q.16 Make a list of the animals you find in the poem “Pretending”

Q.17 Rearrange the jumbled sentences in proper sequence according to the poem

It’s fun to be this,
 To climb like a cat,
 To leap like a lamb,
 It’s fun to be that

Q.18 Write the names of 5 animals/human beings whom you can imitate?

- (1)
- (2)
- (3)
- (4)
- (5)

Q.19 Write how the following creatures move

Example: Tiger - jungle

- 1) Elephant -
- 2) Leopard -
- 3) Monkey -
- 4) Dolphin -
- 5) Bat -

Assignment:-

Q.1 Complete the word web

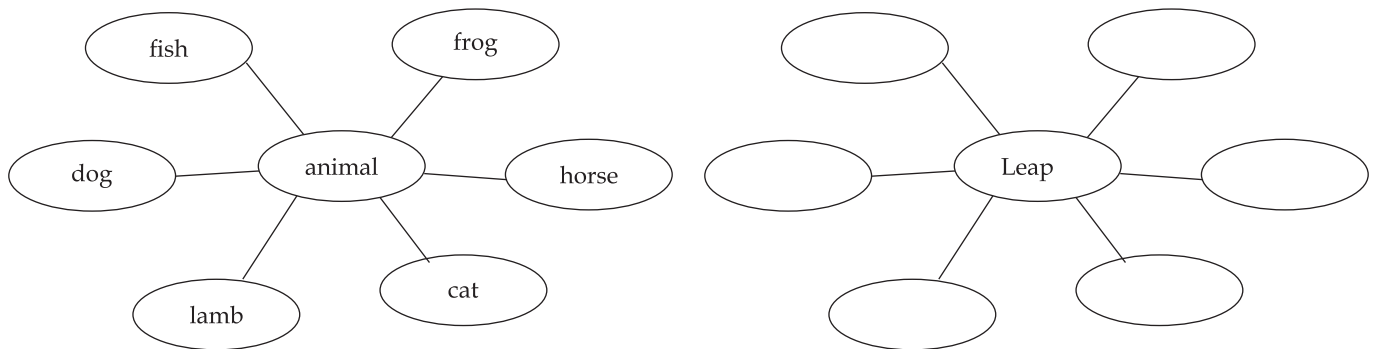

Lesson - 4

A Masai home

Q.1 Fill in the blanks from the given words

- (1) There are number of windows in the Masai house.
(two, no, one)
- (2) In a 'Masai house' kitchen is in the of the house.
(corner, side, center)
- (3) In a 'Masai house' spewal den is the house.
(outside, inside, batlside)
- (4) In a 'Masai house' place of sleeping is in of the house.
(outer corner, inner corner, upper corner)
- (5) The shape of a Masai house is
(square, triangular, rectangular)
- (6) The weather of Masai living place is
(hot, cool, moist)

Q.2 Match the columns

———— Straightline

 Rectangle

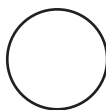
 Circle

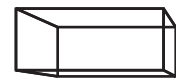

Cube



Triangle



Square

Q.3 Write true and false

- (1) Masai is a tribe. ()
- (2) Masai lives in south Africa. ()
- (3) There is just two room inside a Masai house. ()
- (4) Cattle are an important part of the Masai family. ()
- (5) The Masai women build their homes. ()
- (6) Almost eight people sleep together in one large bed. ()

Q.4 Correct the spellings.

- (1) Esat - east
- (2) liek -

- | | | | | | |
|----------|---|-------|------------|---|-------|
| (3) liev | - | | (4) hsoue | - | |
| (5) dwar | - | | (6) gonrud | - | |

Q.5 Make opposite words

- | | | | | | |
|-----------|---|-------------|-----------|---|-------|
| (1) that | = | <u>this</u> | (2) in | = | |
| (3) dry | = | | (4) like | = | |
| (5) large | = | | (6) inner | = | |

Q.6 Fill in the missing letters (छूटे हुये अक्षरों को भरिये)

- | | | | | | |
|----------------|---|-------|---------------|---|-------|
| (1) t...I...e | - | tribe | (2) s...a...e | - | |
| (3) A...m...st | - | | (4) w...d...w | - | |
| (5) f...e | - | | (6) s...o...e | - | |

Q.7 Make new words (नये शब्द बनाइये)

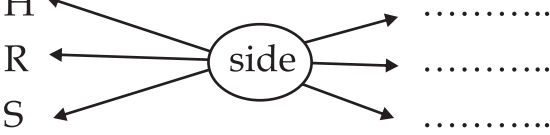
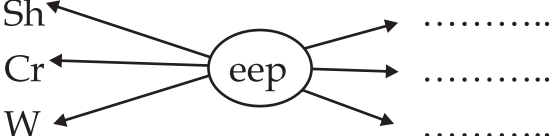
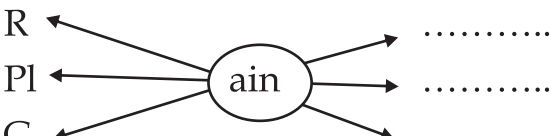
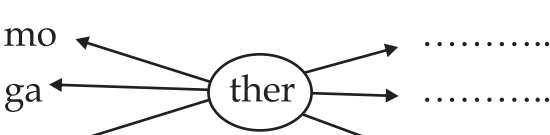
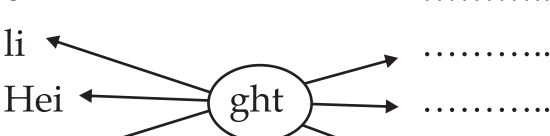
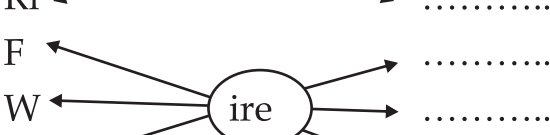
- (1) H ← 
- R ←
- S ←
- (2) Sh ← 
- Cr ←
- W ←
- (3) R ← 
- Pl ←
- G ←
- (4) mo ← 
- ga ←
- o ←
- (5) li ← 
- Hei ←
- Ri ←
- (6) F ← 
- W ←
- T ←

Q.8 Write the meanings in Hindi (हिन्दी में अर्थ लिखिए)

- | | | | | | |
|-----------------|---|---------|-----------|---|-------|
| (1) Tribe | - | जनजातीय | (2) like | - | |
| (3) live | - | | (4) small | - | |
| (5) traditional | - | | (6) near | - | |

(7) their	-	(8) cattle	-
(9) field	-	(10) build	-
(11) over	-	(12) draw	-
(13) shape	-	(14) rectangle	-
(15) ground	-	(16) frame	-
(17) weave	-	(18) together	-
(19) branch	-	(20) rack	-
(21) grass	-	(22) dung	-
(23) over	-	(24) outside	-
(25) keep	-	(26) dry	-
(27) necessary	-	(28) because	-
(29) weather	-	(30) maisf	-
(31) inside	-	(32) Almost	-
(33) large	-	(34) cover	-
(35) hide	-	(36) inner	-
(37) corner	-	(38) centre	-
(39) fire	-	(40) barn	-
(41) warm	-	(42) smoke	-
(43) important	-	(44) Rant	-
(45) family	-	(46) young	-
(47) cult	-	(48) goat	-
(49) recial	-	(50) Dem	-
(51) vessel	-	(52) hollow	-
(53) guard	-	(54) only	-
(55) open	-	(56) light	-
(57) cook	-	(58) long	-
(59) cell	-	(60) drink	-
(61) milk	-			

Q.9 Fill up the blanks according to the shapes given

- 1) A has three corners and three sides
- 2) A has four sides. The opposite sides a rectangle are equal
- 3) A has four corners and four sides. Acc the sides are equal
- 4) A has no corners

Q.10 Make three rhyming words (तीन तुकबंदी के शब्द बनाइये)

- (1) Then - pen, ten, hen
- (2) Dry -,,
- (3) Keep -,,
- (4) pant -,,
- (5) light -,,

Q.11 Complete the table about a masai house

1	Who make it?	<u>Masai women</u>
2	How is it made?	
3	Numper of rooms	
4	Number of people	
5	Number of windows	
6	Number of openings	

Q.13 Write the parts of Tree

Q.14 Draw a picture of Masai home

Q.15 Answer the following questions

- (a) Where do the Masai women sleep?
- (b) Why do they keep the fire burning in their house? Give three reasons

Assignments:-

Q.1 Complete the web by answering the questions

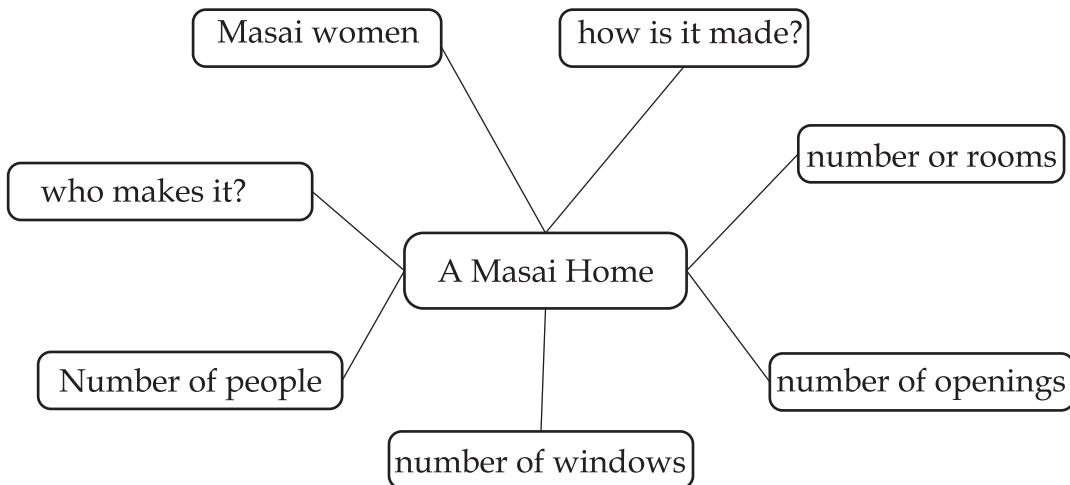

Lesson - 5

Alice in Wonderland

Q1. Circle on the correct word.

- i) There was a _____ girl called Alice.
(small, short)
- ii) She found herself in a _____ hall. (big, large, long)
- iii) One day she had a very strong and _____ dream.
(lovely, fine, interesting)
- iv) A _____ rabbit came running by in a great hurry.
(blur, green, white)
- v) Alice heard and _____ the rabbit and ran after it.
(saw, watched, looked)
- vi) There _____ fell fast asleep. (he, she, it)

Q2. Make new words. (नए शब्द बनाइये)

Wh	←		→	white
B	←		bite	
K	←		kite	
Dr	←		→	_____
Cr	←		_____	
T	←		_____	
f	←		→	_____
l	←		_____	
p	←		_____	
h	←		→	_____
sh	←		_____	
r	←		_____	

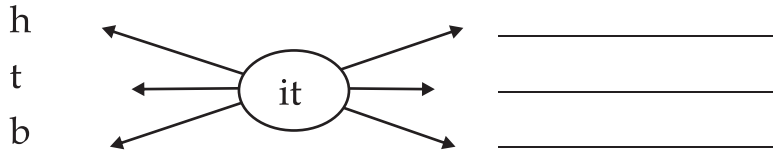
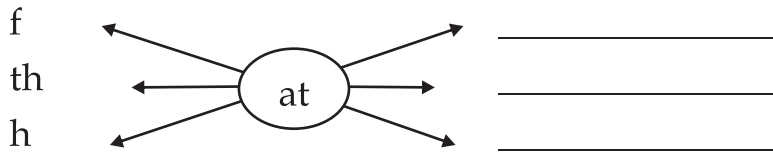

Q3. Add 'ed' in the following words.

- i) Call + ed = called
- ii) Happen + _____ = _____
- iii) Pass + _____ = _____
- iv) Watch + _____ = _____

Q4. Write the meaning of the following words in Hindi.

- i) Once = एक बार
- ii) There = _____
- iii) Strange = _____
- iv) Dream = _____
- v) About = _____
- vi) Upon = _____
- vii) Little = _____
- viii) Interesting = _____
- ix) Hear = _____
- x) Well = _____

Q5. Complete the spelling

- i) S_ra__e = strange
- ii) D__am = _____
- iii) W__r = _____
- iv) A_t_r = _____
- v) R_b__t = _____
- vi) M_d_l_ = _____
- vii) T_em_ = _____
- viii) O_t_i_e = _____

Q6. Write three rhyming words.

- i) Day - ray, say, may
- ii) Lock - _____/_____/_____
- iii) Door - _____/_____/_____
- iv) Side - _____/_____/_____
- v) Back - _____/_____/_____
- vi) Book - _____/_____/_____
- vii) Mousie - _____/_____/_____
- viii) Thin - _____/_____/_____
- ix) Floor - _____/_____/_____

Q7. Using given word think about the spellings of word and make new word as given in the example.

- i) Drum + eam = dream
- ii) _____ + rang = _____
- iii) _____ + llow = _____
- iv) _____ + teresting = _____
- v) _____ + sy = _____
- vi) _____ + bel = _____
- vii) _____ + mble = _____

Q8. Rearrange the letters.

- viii) gerat = great
- ix) hreleasg = _____
- x) colud = _____
- xi) petcock = _____
- xii) gdearn = _____
- xiii) tgouhrh = _____

Q9. The words used in the story for 'small' are.**Assignment-**

- Listen to a fairy tale from your mother, father or grandparents and tell it to your class



Lesson - 6 In the Heart of a Seed

Q1. Write the meanings of given word in Hindi.

Wake, sunshine, world, rose, creep, buried

Q2. Complete the poem with the help of given words.

(*seed, fast, little, seed, deep, world*)

i) In the _____ of a _____

ii) Buried _____ so _____

iii) A dear _____ plant.

iv) Lay _____ asleep.

v) Outside _____ might be.

Q3. Answer the following questions.

i) Who heard the voice of raindrops?

ii) Write the four lines of poem “ In the Heart of a seed” .

iii) Whom does the sunshine wake up every morning?

Q4. Complete the spelling using 'ght'.

(i) Bri = bright

(ii) Li = _____

(iii) Mi = _____

(iv) Fi = _____

(v) Fli = _____

Q5. Match the rhyming words.

(i) Light creep

(ii) Said fear

(iii) Deep fee

(iv) Dear bright

(v) See paid

Q6. Fill up the blanks.

(*water, light, morning, beautiful, fruits*)

i) Raindrops gives us _____.

ii) Sunshine gives us _____.

iii) I wake up early in the _____.

iv) Roses are _____.

v) Plants gives us _____.

Q7. Rearrange the letters and make new words.

I) latpns ii) sfat

iii) rdea iv) ihtgl v) oser

Q8. Write eight lines of the poem “In the Heart of a Seed”.

Q9. Write ‘true’ or ‘false’

i) Plants gives us fruits and flowers.

ii) I wake up at night.

iii) Roses are red in colour.

iv) Sun gives us heat and light.

v) I see with my nose.

Q10. Arrange the words in sequence.

night, wake up, morning, breakfast, dinner, lunch

Q11. Use ‘a’ or ‘an’.

i) This is _____ beautiful rose.

ii) I have _____ apple.

iii) In the heart of _____ seed.

iv) Sita sing _____ song.

v) _____ aeroplane fly in the sky.

Assignment

- Complete the following table-

Creep		Crept
Wept	Wept	
Sweep	Swept	
	Slept	Slept
Keep		kept

- Write six lines about plants.
- How do seeds are grow into a plant?

Project-

- Draw a picture of your favorite fruit and name its parts.



Lesson - 7 Jolly Kittens

Q1. Write the meaning in Hindi.

Bang, suddenly, think, reach, delicious, smell, noise, wash, away

Q2. Add 'ing' and make new word.

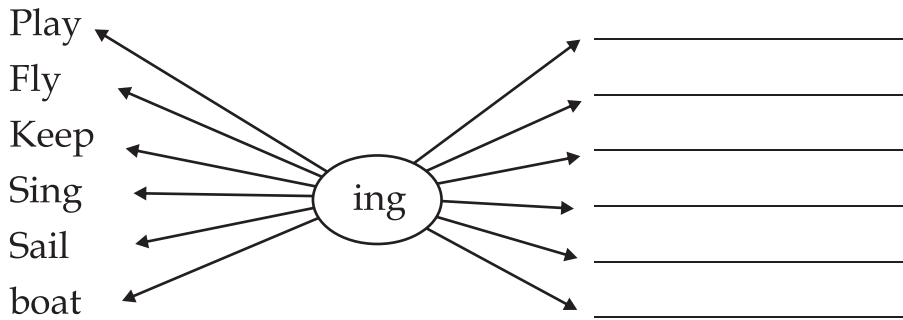

Q3. Complete the table

		Shortest
Elder		
Brave	bolder	
	Taller	
		Biggest
old		

Q4. Match the column.

Send	saw
Think	began
Know	crossed
See	said
Begin	looked
Keep	sent
Want	thought
Come	know
Cross	kept
Say	wanted
Look	same

Q5. Answer the following questions.

- i) What is your name?
- ii) Where do you live?
- iii) How is your teacher?
- iv) When you go to school?

Q6. Make list-

When do you become 'happy'	When do you become 'sad'
----------------------------	--------------------------

Assignment-

- Write about your teacher.
- Write about your school.

Scrap book-

- Draw or paste the picture of –
Plate, bowl, spoon, bucket, bread

Project-

- Ask your children to make a puppy with the help of paper / cloth.

Lesson - 8

The Hare on the Moon

Q1. Match the column Ist form to IInd form(Past tense).

Live	went
Spend	come
Come	said
Tire	lived
Go	spent
Say	tired

Q2. Match the column with punctuation marks.

“ ”	interrogative
.	single inverted comma
?	comma
!	double inverted comma
“ ”	interjection mark
,	full stop

Q3. Look at the picture and state carefully and match the column.

“I am
hungry”

“I have
some nuts”

“I have
some nuts”

“I have a
few fish”

“I have
some fruits”

“I have
some fruits”

The hermit said " I am hungry"
 The otter said "I have a few fish."
 The monkey said " I have some nuts."
 They have said, " I have some grass."
 The boy said, " I have some fruits."
 The girl said, " I have some chocolate"

The girl said that she had some chocolate
 The hare said that he had some grass.
 The hermit said that he was hungry.
 The otter said that he had a few fish.
 The girl said that she had some chocolate.
 The monkey said that he had some nuts.

Q4. Choose the correct words from the box

Rice, pens, biscuits, salt, match, boxes, sugar, oil, candles, butter, pencils, milk, apples

- | | |
|--------------------------|--------------------|
| i) <u>A little</u> rice. | ii) A little _____ |
| A few <u>pens</u> . | A few _____ |
| iii) A little _____ | iv) A little _____ |
| A few _____ | A few _____ |
| v) A little _____ | vi) A little _____ |
| A few _____ | A few _____ |

Q5. Match the column I st form to II nd form.

Have	brought
Can	made
Do	stood
Bring	had
Make	could
Eat	did
Jump	flew
Look	ate
Stand	jumped
Take	looked
Flow	took

Q6. Fill in the blank using 'a' and 'an'

- | | |
|------------------|------------------|
| i) A hare. | ii) _____ angle. |
| iii) _____ book. | iv) _____ pen. |
| v) _____ orange. | vi) _____ owl |

Q7. Rearrange the letters

- | | | | |
|-----------|---------------|------------|-------|
| i) hgurny | <u>hungry</u> | ii) htmire | _____ |
|-----------|---------------|------------|-------|

- iii) meknoy _____ iv) feri _____
 v) pesale _____ vi) fserot _____

Q8. Write the meanings of given words in hindi.

Tired, grass, smile, struck, together, stone, fire, arm

Q9. Write about hermit in your own words.

Assignment-

- Complete the following table.

Eats only plants (herbivores)	Eats only flesh (carnivores)	Eats both flesh and plants (omnivores)

- Draw a picture of Hermit.

Scrap book-

Draw or paste the picture of – Monkey, Hare, otter

Project-

- Translate the dialogue between the hermit and the hare into your mother tongue.
- “The hare jumped into the fire. This was the right thing to do.” Have a debate on this topic in your mother tongue.



Lesson - 9

Running and Shouting

Q1. Make sentences using the table below-

The child is running and shouting	In Down Up Near	The lane
		The field
		The hill
		The lake
		The stream
		The sun
		The rain
		The night

Example:- The child is running and shouting in lane.

Q2. Make the three rhyming words

Sun, hill, keep, no, rain, and

Q3. Write the missing letters.

i) b_c_u_e = biscuit

ii) s_r_am =

iii) s_o_t =

iv) n_i_e =

v) t_e_e =

Q4. Rearrange the letters.

i) csors - cross

ii) fleid - _____

iii) sucht - _____

iv) saertm - _____

v) bsueace - _____

vi) auobt - _____

Q5. Circle the odd one.

i) Orange, banana, lotus, grapes

ii) Rose, marigold, lily, pomegranate

iii) Dog, cat, bear, cow

Lesson - 10

Jagatu The Gardener

Q1. Say if the following statements are right or wrong.

- (i) Jagatu was not amazed to see the elephant.
- (ii) Jagatu's wife asked him to bring more betel leaves.
- (iii) The villagers were eager to go to heaven.
- (iv) Airavat was heavenly body.

Q2. Match the following words in 'A' with their opposites in 'B'.

A	B
Ascend	Small
Enormous	Dropping
Picking	Unemployed
Deport	Descend
Employed	arrive

Q3. Match the following words with their opposites.

- | | |
|-----------|-------|
| Beautiful | death |
| Enormous | sad |
| Night | ugly |
| Life | small |
| Happy | day |

Q4. Choose the appropriate words from the box and fill in the blanks.

insist on, climb, enormous, employee

- i) The new _____ in our office works sincerely.
- ii) The African elephants are the most _____ elephants in the world.
- iii) Why do you _____ me to complete this exercise today?
- iv) _____ these steps and you will be on the top floor.

Q5. Fill in the blanks with the words given in the bracket.

Once upon a _____ (crime / time), there was a gardener called _____ (Maglu / Jagtu). He was employed in the king's _____ (garden / field). It was a _____ (ugly / beautiful) garden. Jagatu used to spend the _____ (whole / hole) day in the garden.

Q6. Fill in the blanks with the words given in the brackets.

One _____ (day / night), however, he had to remain in the garden. Suddenly _____ (she / he) heard a loud noise. Jagatu hid himself behind a _____ (big / small) tree in great fear. He saw a large _____ (Bear / Elephant) descending from the sky. It was roaming about _____ (in / on) the garden.

Q7. Make some meaningful words from 'vegetables' as has been done in the case of 'Beautiful'.

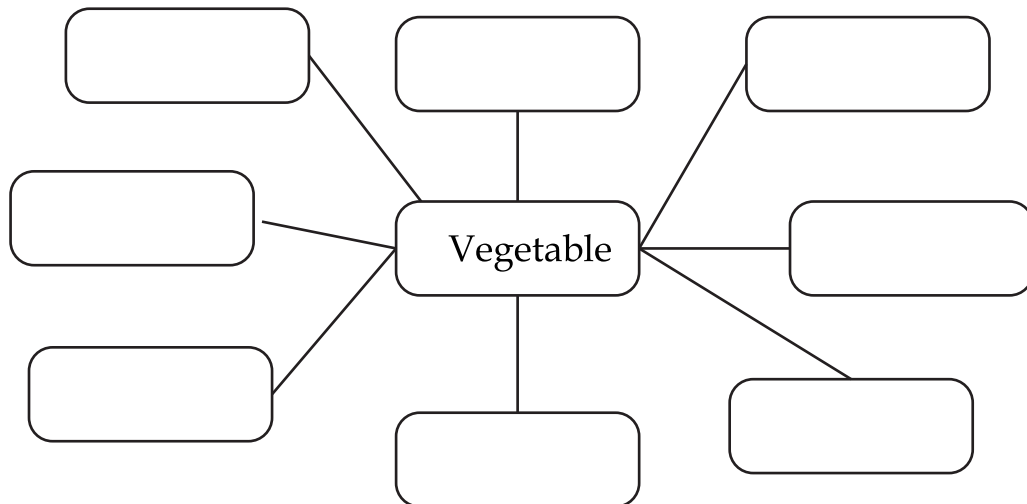
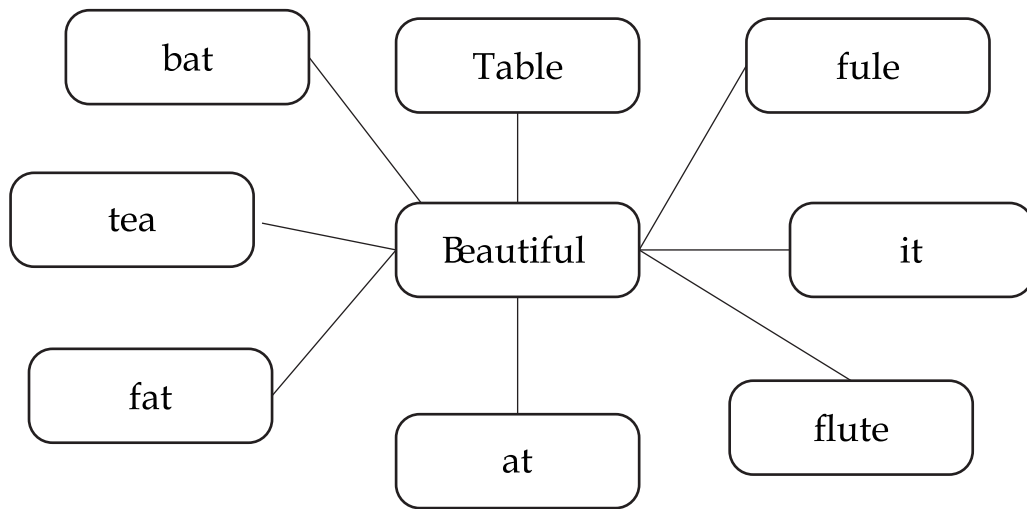

Q8. Write words ending with 'er'

Example- garden + er = gardener

(i) _____

(ii) _____

(iii) _____

(iv) _____

Q9. Write words ending with 'r'

Example- manage + r = manager

(i) _____

(ii) _____

(iii) _____

(iv) _____

Portfolio-

- Make a list of things that you see flying in the sky.
- Draw a picture of an elephant.

S.no	Day		Night		Both day and night	
	Living	Non living	Living	Non living	Living	Non living

Scrap book.

- Draw or paste a picture of an elephant.
- Draw a picture of a garden.



Lesson - 11

Left in Charge

Q1. Write true/false against each of the statements.

- | | |
|---|-----|
| i) Bhola did his work well. | () |
| ii) His parents were angry with him. | () |
| iii) The animals and birds did not complain about any things. | () |
| iv) The ducks fed themselves. | () |
| v) The kid did not get water. | () |
| vi) The rabbit was in the well. | () |
| vii) The calf did not eat the vegetables patch. | () |
| viii) The chicks makes noise – ‘kut – kut kuttaka koon’. | () |
| ix) Daduna was sleeping in the sunshine. | () |
| x) Maa and Bapu had put on their new cloths. | () |

Q2. Match the following

Eat	Quack – Quack
Blink	bells
Move	feed
Noise	eye
Jingling	waving hand

Q3. Match the following

Loud	flapping
Eye	jingling
Green leaves	barking
Wings	blinking
Bells	chewing

Q4. Answer the following questions

- i) Bhola was not going to town with his parents but he was very happy. Why?
- ii) Bhola was left behind at home to do a lot of work. Make a list of the things he had to do.
- iii) Write the things Bhola asked his parents to bring from the town market.
- iv) Why did Bhoal's parents smile at the end?
- v) Who warned Bhola to feed the cattle and the bird?
- vi) Who was sleeping in the sunshine?
- vii) Where did Bhola kept his basket of corn?
- viii) Who makes the noise of 'kut – kuttaka koon'?
- ix) Did Bhola was happy?
- x) Give one word movement of hand to say good bye.

Q5. Who said? Tich the correct answer.

- i) "Take care of Dadima." (mother / father)

- ii) "Don't forget to feed the cattle and the birds." (father / mother)
- iii) "Give her medicine on time." (father / mother)
- iv) "Oh, my God! what have you done, Bhola." (mother / Dadimaa)
- v) "So, out little one 'left incharge', how was the day?" (Bhola / Dadimaa)
- vi) "Oh! you want some grass." (mother / father)
- vii) "Give her warm milk." (father / mother)
- viii) "Quack -Quack." (ducks / calf)
- ix) "Mo-oo-oo" (kid / Calf)

Q6. Match the following

Duck	bulk
Calf	mo-oo-oo
Kid	kut -kut kuttakakoon
Dog	quack-quack
Chick	mein.....

Q7. Read the following sentences and match it with proper instruction.

(i) Take care of Dadima	warn
(ii) Use the washing machine once a weak	bless
(iii) Please, open the door	advice
(iv) Be aware of dogs	order
(v) May you live long	request

Q8. Arrange the following sentences in sequence according is the story

- i) They were going to town to sell the vegetable grown in their small field.
- ii) Maa and Bapu had put on their new clothes.
- iii) He was not going with his parents.
- iv) Bhola was very happy.
- v) He was left in charge to take care of Dadima, a calf , a kid , a rabbit , ducks, a hen with chicks and the small vegetable field.



Lesson - 12

Who has seen the wind?

Q1. Choose the correct from the bracket and complete the poem

(seen, leaves, nor, clind, passing)

Who----- the -----.

When the ----- hang trembling.

The wind is ----- by through.

Neither you----- I.

Q2. Write the missing letters and complete the spellings given below

(i) N__ th_ r

(ii) d__ wn

(iii) H__ ds

(iv) h____ ng

(v) Tr_ m bl_ ng

Q3. Complete the spellings with the help of 'ing'

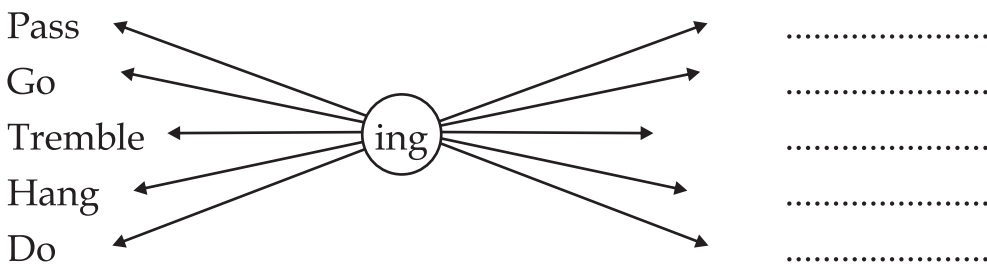

Q4 Write the meaning of followings words in hindi

(i) passing seen

(iv) Bow down

(vi) Hang

(ii) tremble

(v) Throught

(vii) Wind

(iii) through

Q.5 Rearrange the letters

(i) h w n e

-

(ii) I n w d

-

(iii) I t h e r

-

(iv) r o n

-

(v) a v l s e e

-

Q.6 Answer the following questions:-

(i) Has anyone seen the wind?

(ii) Write the 6 lines of poem "Who has seen the wind"

(iii) How do we know that the wind is passing by?

(iv) Which seems to be stronger the wind or the tree?

(v) Who has seen the wind?

Q.7 Add 's' and complete the words given below:-

- | | |
|---------------|--------------|
| (i) head - | (ii) tree - |
| (iii) seem - | (iv) leave - |
| (v) answer - | (vi) know - |
| (vii) speak - | |

Q.8 find out the given words in puzzle and circle it.

(down, owl, spell, girl, hen, doing, nor)

- | | | |
|-----------------|----------------|---------------|
| (i) S d o w n | (ii) P o w I o | |
| (iii) E I l n r | (iv) L n h e n | (v) I g I r i |

Project/portfolio

- Q1. Draw a picture of a tree with leaves
- Q2. Draw a picture of sky and birds.
- Q3. Draw/paste a picture with the help of leaves.

Assignment

- Q1. Write the uses of tree in our life
- Q2. Write 10 lines about wind.
- Q3. Write 5 lines about leaves, their shapes colour and uses.
- Q4. Are trees useful for us? If yes / no give reason



Lesson - 13

Gopal Bhand and Mahagyani

Q.1 Choose the correct option and put a tick mark (-) on it.

- (i) Raja Krishna Chandra ruled over a part of -
 (a) Bengal (b) Gujrat
- (ii) Gopal Bhand was a
 (a) Minister (b) court Jester
- (iii) A learned man who came to the court was
 (a) Tenali (b) Mahagyani Pandit
- (iv) The king was going to honor Mahagyani with a garland of ----
 (a) Roses (b) lily
- (v) Mahagyani shouted at Gopal Bhand in-----
 (a) American tongue (b) mother tongue

Q.2 Write true/false in the bracket.

- (i) Gopal Bhand knew many languages. ()
- (ii) Mahagyani was a proud man. ()
- (iii) The king had many scholars in his court. ()
- (iv) The pandit had good knowledge of dance and music. ()
- (v) Raja Krishna Chandra ruled over Bengal. ()

Q.3 Choose the correct word from the bracket and fill in the blanks

[alert, fluently, scholar, jester, identified,]

- (i) Gopal bhand was a in the court of the king raja Krishna Chandra.
- (ii) Everyone speaks one's mother tongue
- (iii) Dr. S. Radhakrishna was a great
- (iv) Travellers should be about their luggage while traveling.
- (v) The police the thief by his clothes.

Q.4 Find the words

- (a) My first letter is in **tap** and **set**
 My second letter is in **read** and not in **lead**
 My third is in **sit** and in **him**
 My fourth letter is both in **pot** and **pan**

Who am I -----

(b) My first letter is **hat** and **hen**

My second letter is ' I '

My third letter is in **dog** and **din**

I am mr -----

(c) My first letter is in **who** and **walk**

My second letter is in **sit** and not in **pit**

My third letter is **s**

My fourth letter is in **he** and **ten**

Who am I -----

(d) My first letter is

My second letter is in **be** and **pen**

My third letter is in **go** and not in **to**

Who am I -----

(e) My first letter is in **rat** and **ring**

My second letter is both in **ant** and **axe**

My third letter is **n**

Who am I -----

Q.5 Match the rhyming words

- | | | |
|--------|---|-------|
| 'A' | | 'B' |
| Hid | - | nice |
| Scream | - | kid |
| Trap | - | hedge |
| Edge | - | cream |
| Wise | - | scrap |

Q.6 Add "ly" and make new words

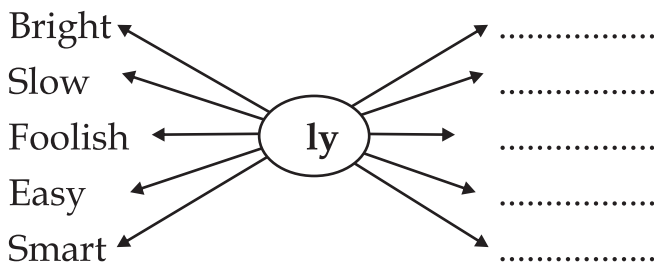

Q.7 find these words in puzzle and circle it

[cout, king, hid, rose, garden]

C o u r t p q
K l r o s e n

R s t k l n g
A e h j o t u

H I d u v x y
G a r d e n z

Q.8 write the missing letter and complete the spelling.

1. __ rip

2. Ga__lan__

3. __ ise

4. S__hol__r

5. S__ __ rt

Q.9 Match the words with their meanings

'A'

'B'

(i) Jester

.....

(ii) Garland

.....

(iii) Hedge

.....

(iv) Wise

.....

(v) Ideatity

.....

Q.10 Make sentences with the help of following information.

Example: Seema - speak - perfect

Sentences: Seema speak perfectly.

Sita - write - fluent

Ashu - read - nice

Pradip - sing - beautiful

Kavya - talk - smart

Manoj - smile - slow

Q.11 Read the passage carefully and write few lines using given clues:

Lions are members of the cat family. They live in Africa and india. The lion is a big cat. It is about 3 meters long and weighs than 200 kilograms .it is yellow in colour. The lion can swim in water and climb up trees. It eat only M e a t . I t hunts animals like the zebra. It kills animals by using its claws and teeth. The lion lives for about fifteen years. Using the clues given below write the description of a TIGER.

CLUES:

..... cat family..... indiaBig cat
..... 3 meters..... 250 kilograms.....Yellow
both male and female have black strips.and jump very well
powerful claws lives 15 years.

Q.12 Answer the following questions

- i) Who was Gopal Bhand
- ii) Why did the Raja announce a reward?
- iii) Why did Gopal Bhand hide himself behind the hedge?
- iv) Why was the king angry?
- v) Why did the pandit curse Gopal Bhand?
- vi) Which language did the pandit curse Gopal Bhand in?

Q.13 Give answer of following questions in one word.

- i) Who ruled over a part of Bengal?
- ii) Who was a court fester?
- iii) Who came to the court?
- iv) in which language pandit curse Gopal Bhand ?

Q.14 Use the information given in the table and write s sentences about your Friend. One is done for you.

Example: Neha always gets up early

Gets up early	always
Reads books	always
Tells lies	some times
Paints pictures	often
Watches t.v	usually
Plays tennis	never

Assignment

1. Using the clues given below write the description of a leopard.+

Clues:

..... cat family india Big bat
 meters kilograms..... Yellow.....
 and jump very well
 Meat claws and teeth live Years.

2. Write 5 words which ends with "ly"

Portfolio

1. Collect - A funny story from a news paper or magazine and write / paste It on the chart paper for your class.



Lesson - 14

Puppy and I

Q1. Choose the correct option and put a tick mark () on it.

- (i) The moon was going to get _____
 (a) bread (b) chocolate
- (ii) The horse was going to get _____
 (a) grass (b) hay
- (iii) The woman was going to get _____
 (a) barley (b) rice
- (iv) The rabbits are going to get _____
 (a) oats (b) carrot
- (v) In the lesson 'I' stands for
 (a) puppy (b) child

Q2. Match the rhyming words in column 'A' to column 'B'

A	B
Big red house	new red tie
Brown fur coats	white tiny mouse
Golden day light	new green notes
Dark cloudy sky	little bright kite

Q.3 Choose the correct word from the bracket and fill in the blanks:

[horse, rabbits, man puppy, woman]

- i) I met a _____ who was going to get some bread.
- ii) I met a _____ who was going to get some hay.
- iii) I met a _____ who was going to get some barley.
- iv) I met a _____ who was going to get some oats.
- v) I met a _____ who was going up in the hills.

Q.4 Match the columns

A man	going up in the hills
A woman	going to get some oats
A horse	going to get some hay
Some rabbits	going to get some bread
A puppy	going to get some barley

Q.5 Choose the correct word from the given pairs and complete the Rhymes:

Pears - curls flowers - towers Beat - treat cheese - these

- i) The little girls, Had teeth like _____
- ii) The clouds bring showers, To the thirsty _____
- iii) They moved their feet, To the drum's loud _____
- iv) He says he afrees, With those but not _____
- v) Most little boys, Make a lot of _____

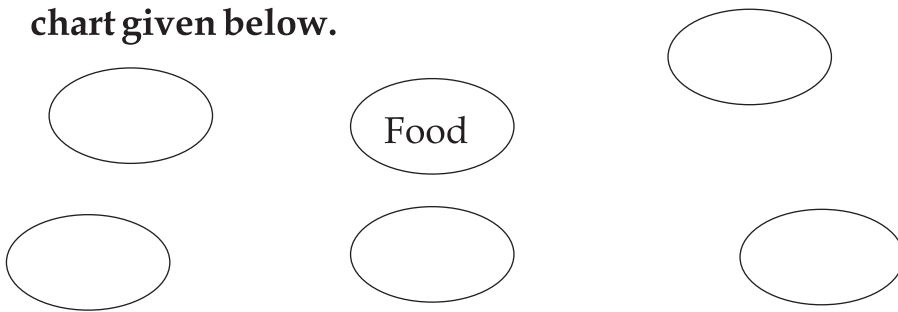
Q.6 Pick out the words from the poem related to food and put them in the Web chart given below.**Q.7 Write the missing letters and complete the spelling.**

1. V _ ll _ ge 2. b _ own 3. Br _ _ a _ _
4. O _ _ _ s 5. s _ _ n _ _ 6. _ _ a _ _ k

Q.8 Write the meanings of following words in Hindi.

- | | | | |
|---------|-------|------------|-------|
| 1. Met | | 2. Village | |
| 3. Walk | | 4. Talk | |
| 5. Hay | | 6. Barley | |
| 7. Fur | | 8. Oats | |
| 9. Hill | | 10. Nice | |

Q.9 Write the name of these things which you can count in countable noun and you can't count in uncountable noun column

[tree, milk, sand, chairs, pen, sugar, hair, table, star, cae]

Countable nouns

uncountable noun

- 1.
- 2.
- 3.
- 4.
- 5.

Q.10 Answer the following questions:

- (i) In the lesson who does 'I' stand for?
- (ii) Why does the child talk to everyone he meets on his way?
- (ii) Where did the pussy was going?
- (iv) Who was going to get some hay?
- (v) Who was going to get some barley?
- (6) Rabbits were going for what?
- (7) Man was going for what?
- (8) List the names of all those who said, "will you come with me / us"
- (9) What is the question that the child asks every one he meets?
- (10) Write the opening line of each stanza.

Q11. Add "ing" and make new words.

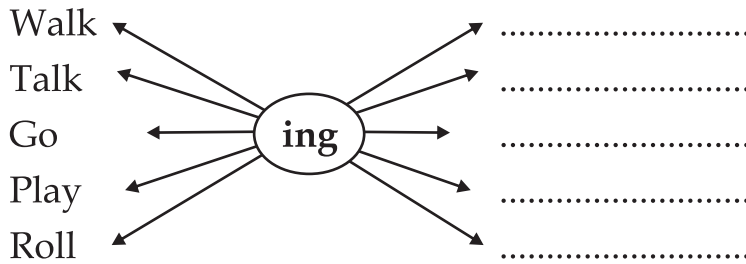

Q12. Who said?

- i) I met a man as I went walking.
- ii) "Down to the village, to get some bread."
- iii) "Down to the village, to get some bay."
- iv) "Down to the village, to get some oats."
- v) "Up in the hills to roll and play."

Q13. Tick the correct rhyming word given in the bracket.

- i) Walk (talk / chat) ii) Go (yes / no)
- iii) Hay (say / hair) iv) Oats (coats / hat) v) Hill (chair / bill)

Assignment-

- i) Write five countable nouns. ii) Write five uncountable nouns.
- iii) Write the name of five food items.

Portfolio

- i) Draw / paste a picture of a puppy.
- ii) Draw / paste a picture of a rabbit.



Q4. Choose the correct word from the bracket and complete the sentence.

Sugar, cake, milk, chalk, ice

- i) A slice of _____
- ii) A bottle of _____
- iii) A cube of _____
- iv) A piece of _____
- v) A lump of _____

Q5. Write these things in the correct columns.

Stars, apple, milk, chocolate, paper, juice, chair, book, hair, sugar

Things we can count	Things we can't count

Q6. Write True/False in the bracket.

- i) Jerry and Bruce are friends. (_____)
- ii) Bruce found a nickel. (_____)
- iii) Jerry want to buy a present for his mother. (_____)
- iv) Jerry buy a crushed loaf. (_____)
- v) Sally liked Jerry's gift. (_____)

Q7. Write the missing letters and complete the spelling.

- | | |
|--------------|---------------|
| i) N_ck_l | ii) Di_est_r_ |
| iii) Lo__ | iv) G_m |
| v) _rowd | vi) Gi_t |
| vii) Sp_ci_l | viii) Hon_y |
| ix) _ost | x) Won_er_ul |

Q8. Write the meaning of following words in Hindi.

Nickel,	honey,	Gift,
Shopping,	Cost,	Crowd,
Crushed loaf,	Surprise,	Birthday

Q9. Answer the following questions.

- i) Who found a nickel?
- ii) Who were Jerry and Bruce?
- iii) What did Jerry want to do for his little sister?
- iv) Why did his friend laugh at him?
- v) Why couldn't Jerry buy a gift for his sister from the toy store and the dime store?
- vi) What did he decide to buy for his sister on her birthday?
- vii) Did his sister accept the gift?
- viii) What did Sally do with the gift?



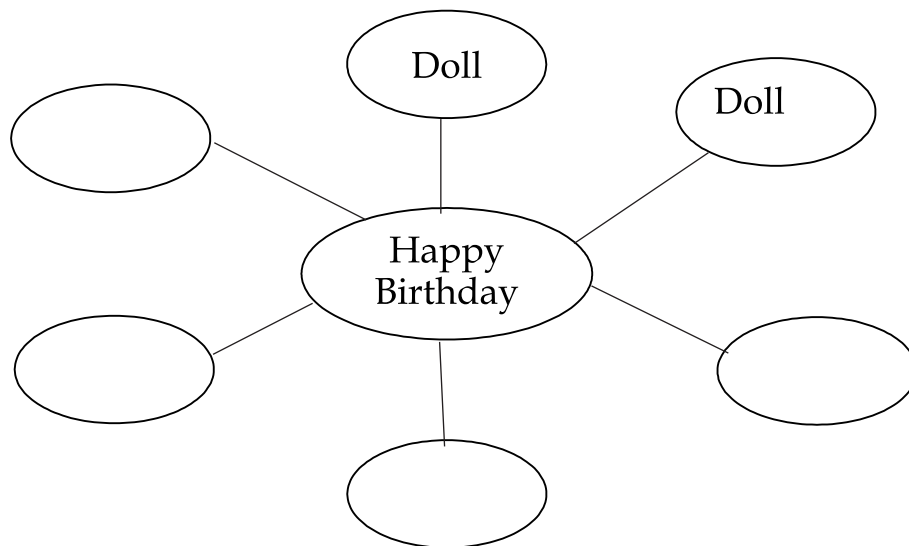

Q10. Complete the word web with the names of some gifts that one may receive or give on a birthday.



Lesson - 16

Women for Trees

Q1. Match the words with picture.

A	B	
Stumps	poacher	
Graze	timber	
Timber	twigs	
Twigs	grazing cow	
Poach	two stumps	

Q2. Arrange the letters to make words related with the given words.

- i) Wood: _____
 (mbreti) (tcisk) (glo) (gtwi)
- ii) Fuel: _____
 (rbun) (wdoo) (sga) (rtpole)
- iii) Sprout: _____
 (rgwo) (ngbei) (emrgmitae)

Q3. Write true/false in the boxes.

- i) The Mahila Mandal was formed in the year 1998.
- ii) We should be thankful to the insensitive people who fell trees.
- iii) Now the women cut the trees for fuel and wood.
- iv) The women dug trenches around the forest.
- v) Other people of Bhalapur also tried to do what the women of the village did.
- vi) The women of Mahila Mandal were invited.
- vii) The women had to work hard to protect the forest.
- viii) The women had to protect the trees against animal only.
- ix) Bhalapur is a village of Rajnandgaon district.
- x) Mohan of Bhalapur organized all the women in the village.

Q4. Choose the correct word from the bracket and fill in the blanks.

Forest, Rajnandgaon, wood, adivasis, trenches

- i) Bhalapur is situated in _____ district.
- ii) Largely dalits and _____ were members of Mahila Mandal.

Q7. Write the meaning of following words in Hindi.

Fuel	protection	Inspore	Mafia
Poacher	Timber	Bio-diversity	Stump
Problem	Fire wood		

Q8. Some sentences are given below about making tea. Arrange these sentences in the right sequence.

- Add four teaspoons of sugar.
- Add two teaspoons of tea leaves.
- Pour water into a vessel or a container.
- Put the vessel on the fire.
- Remove from the fire and filter it in a cup.
- Add one cup of milk.
- Take a cup of water.
- If you like, add some ginger.
- Grate / crush some ginger.
- Boil it.

Q9. Write a paragraph about making tea. Things are given below which you need for making tea.

Tealeaves, sugar, water, milk, ginger

Q10. Complete the word web.

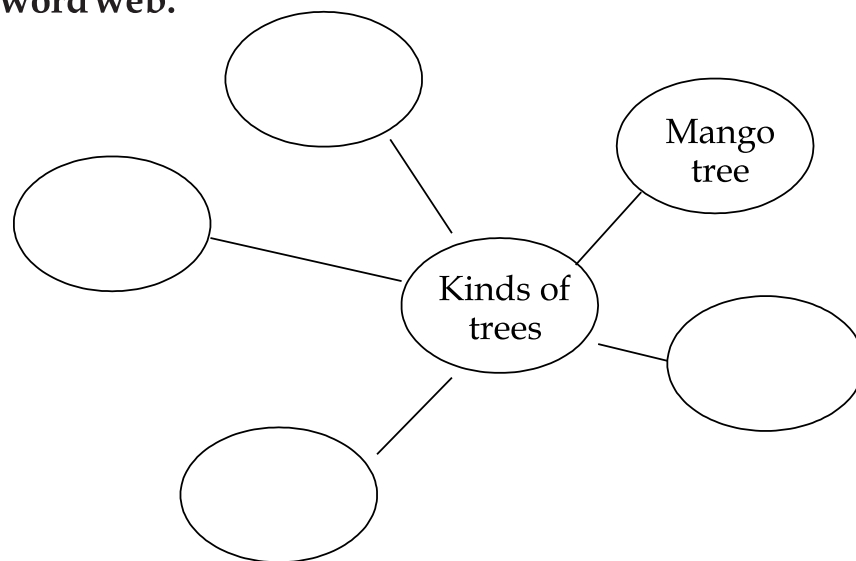

Q11. Answer the following questions

- i) Where is Bhalapur situated?
- ii) Who were the members of the Mahila Mandal of Bhalapur?
- iii) What was the greatest problem that the women faced?
- iv) Why was the village forest shrinking?
- v) What did the woman do to protect the forest from grazing animals?
- vi) What is the result of the efforts made by the women of Bhalapur?
- vii) Write the name of four things which we use as fuel?
- viii) Write the name of four things related with " wood".

Q12. Circle the word which sounds different.

- i) Block, clock, Hand
 ii) Land, Say, Band
 iii) Fire, Hire, Call
 iv) Chat, fell, Tell
 v) Trench, Talk, Bench

Q13. Here are some activities given below in the boxes that Ravi and Kusum did last week between 7 am and 9 pm. Using the information write three or four sentences about each other.

i)

	Monday	Tuesday	Wednesday
Ravi	Went to jungle for collecting wood	Milked cows	Played with his friends
Kusum	White washed her house	Played with her friends	Collected vegetables from fields

ii)

	Monday	Wednesday	Friday
Ravi	Went to temple	Watered plants	Watched movie with his friends
Kusum	Stitched her dress	Went to market for shopping	Cleaned her home

- Write the names of things which trees give us



Lesson - 17

Little drops of Water

Q1. Choose the correct word from the bracket and complete the poem.

Ocean, drops, sand, land, drops

- i) Little _____ of _____,
- ii) Little grains of _____,
- iii) Make the mighty _____,
- iv) And the pleasant _____

Q2. Match the columns and make compound words

A	B
Drops	of love
Grains	laud
Mighty	of water
Pleasant	of kindness
Deeds	of sand
Words	ocean

Q3. Add "s" and make new words

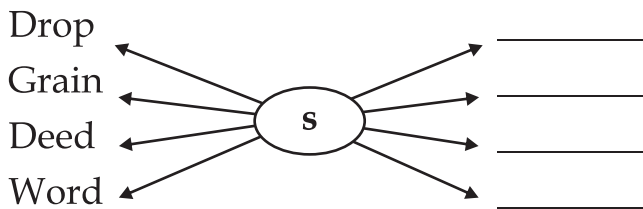

Q4. Write the missing letters and complete the spelling.

Dr__p w__ter gra__n san__

Might__ __cean l__nd __ove

Ea__th hea__en

Q5. Write the meanings of these words in Hindi.

Drop, grain, sand, mighty, ocean,
 Pleasant, Kindness, earth, heaven, hand

Q6. Write true or false.

- i) Little drops of water make the mighty ocean. (___)
- ii) Little grains of salt make the pleasant land. (___)
- iii) Little deeds of kindness make our earth like hell. (___)

- iv) Little words of love make our earth an eden. (___)
 v) Heaven is compared with the earth. (___)

Q7. Circle the word which sounds different.

- i) Water, potter, car
 ii) Cow, hand, land
 iii) Top, caught, drop
 iv) Rain, train, lock
 v) Earth, talk, birth

Q8. Choose the correct word from the bracket and fill in the blanks.

- i) Little drops of ___ make the mighty ocean. (water / potter)
 ii) Small _____ makes a big house. (top / bricks)
 iii) A number of _____ make a garland. (flower / tower)
 iv) Little grains of _____ make the large desert. (band / sand)
 v) 60seconds make a _____ (minute / hour)
 vi) 100 paise make a _____ (rupee / hundred)
 vii) Small blades of _____ make the bird's nest. (leaf / grass)

Q9. Write words that end with these letters in the blank boxes.

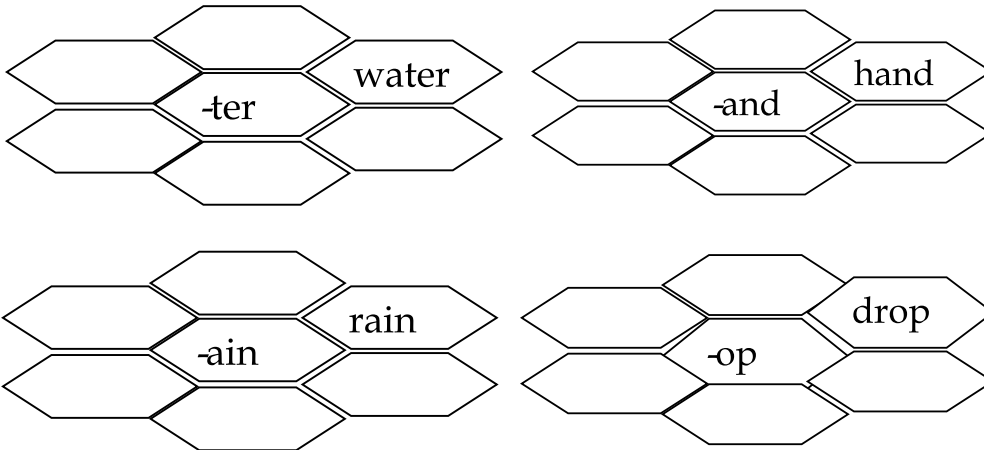

Q10. Answer the following questions

- i) What is the mighty ocean made of?
 ii) What is the pleasant land made of?
 iii) What can make our earth an Eden?
 iv) What has been compared with the earth?



प्रश्न बैंक
अंग्रेजी

कक्षा - 7

Lesson - 1

Hobble Bobble

Q1. Match the column according to the poem

Woke-up	telephone
Ate	bus stop
Drunk	morning
Went	cup of tea
Broke	a slice of a bread

Q.2 Write the meaning in Hindi

Morning,	bed,	school,	bicycle,	pool,
friend,	evening,	ceiling,	read	

Q3. Choose the correct rhyming.

- i) Morning
(a) night (b) evening
- ii) Bread
(a) Bed (b) bat
- iii) School
(a) Coal (b) pool
- iv) Friend
(a) End (b) Kind
- v) Radio
(a) Video (b) cheat

Q4. Fill in the blanks with the given words.

Ceiling, read, evening, watched, crazy

I came here this _____ and _____ the radio, I lay down on the _____ and _____ a video. Oh! What a day.

Q5. Choose the correct word from the brackets and fill in the blanks.

- i) I _____ up this morning. (woke / wake)
- ii) I _____ into bed. (get / got)
- iii) I _____ a cup of tea. (ate / eat)
- iv) I _____ a slice of a bread. (drink / drank)
- v) I _____ to the bus stop. (go / went)

Q6. Circle the naming word.

- i) I got into bed.
- ii) I ate a cup of tea.
- iii) I went to the bus stop.
- iv) I caught the train to school.
- v) We went to the football field.
- vi) I lay down on the ceiling.

Q7. Match the column "A" with the tenses in column "B"

Get	→	go
Eat	↗	woke up
Drink	↘	got
Went	↙	ate
Wake up		drank

Q8. Circle the second form of verb in the following sentences.

- i) I wokeup this morning.
- ii) And I got into bed,
- iii) Then I ate a cup of tea
- iv) And drunk a slice of bread
- v) I went to the bus stop
- vi) And caught the train to school.

Q9. Teacher will dictate five words.

Q10. Write two things the child does in a strange way.

Example- ate a cup of tea.

Q11. Re-arrange and write in correct sequence.

I woke up this morning.

Then I ate a cup of tea.

And drank a slice of bread,

And I got into bed,

Q12. Make new word by adding "ing"

- | | | | |
|----------|-------|-----------|-------|
| i) Read | _____ | ii) Watch | _____ |
| iii) Eat | _____ | iv) Catch | _____ |
| v) Drink | _____ | | |

Q13. Write the name of five things which you drink.

Example- water

- I) _____ ii) _____
 iii) _____ iv) _____ v) _____

Q14. Write the five things which you eat in your break fast.

Example- bread

- i) _____ ii) _____
 iii) _____ iv) _____ v) _____

Q15. Write five lines of the poem you like.

Q16. See the picture carefully and write the lines from the poem under the related picture.

Example-

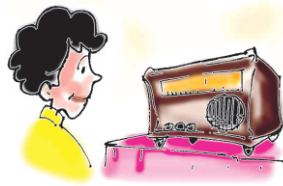

Watched the radio



.....



.....



.....



.....

Q17. Give the correct words for the following underlined words.

Example- got into bed.

Got out of bed.

- i) Ate a cup of tea.
- ii) Drunk a slice of bread
- iii) Caught the train to school.
- iv) Watched the radio.
- v) Read a video

Q18. Complete the word web with the second form of the verbs (past tenses) which occur in poem.

Q19. Write down the second form (past forms) of the following verbs.

Walk, say, sit, keep, write, come

Q20. Look at the picture and write the action word.



Walking.....



Lesson - 2

The Missing Whistle

Q1. Write the meaning of following words in Hindi.

Piglet, lunch, door, pushed, inside, mess, round, search, whistle, under, cupboard, anywhere, grumble, pile, throw, tidy, fetched, smell, laughed

Q2. Fill in the blanks

- i) Piglet went to see _____. (rabbit / cat)
- ii) At last the _____ opened. (window / door)
- iii) I've lost my _____. (whistle / ball)
- iv) Rabbit _____ a bowl of poha. (searched / fetched)
- v) It was _____ in the poha. (hiding / fighting)

Q3. Give the full forms of the following

Example- couldn't = could not

- i) I've = _____
- ii) Can't = _____
- iii) I'll = _____
- iv) I'm = _____
- v) We'd = _____
- vi) He'd = _____
- vii) Didn't = _____

Q4. Tick the correct answer

- i) When Piglet could not open the door, he-

(a) knocked the door	(c) pushed the door
(b) kicked the door	(d) went back
- ii) Piglet went to see the rabbit-

(a) before lunch	(c) before breakfast
(b) after lunch	(d) after dinner
- iii) Rabbit lost his whistle

(a) at night	(c) in the evening
(b) at noon	(d) in the morning

- iv) The whistle was hiding
 (a) In the poha (c) in the milk
 (b) In the rice (d) in the soup
- v) The lesson is about
 (a) The missing piglet (c) the missing pen
 (b) The missing rabbit (d) the missing whistle

Q5. Add "ing" to the following word

Example- smell + ing = smelling

- i) Bring + _____ = _____
 ii) Climb + _____ = _____
 iii) Eat + _____ = _____
 iv) look + _____ = _____
 v) pick + _____ = _____
 vi) drink + _____ = _____
 vii) search + _____ = _____

Q6. Teacher will dictate ten words from the lesson.

Q7. Fill in the missing letters to complete the incomplete word.

- i) L__nch ii) Pi__let
 iii) Pus__ed iv) t__dy
 v) Dra__er vi) wh__stl__
 vii) Ta__le viii) ra__b__t
 ix) Cu__bo__rd x) Th__own

Q8. Two words are given. Put (✓) tick mark in the space provided if the word rhyme with each other and (x) cross mark if they don't.

Example- *night - kite* (✓)

- i) Cry - dry () ii) Grumble - scramble ()
 iii) Lunch - bunch () iv) Fetch - catch ()
 v) Mess - guess () vi) File - fail ()

Q9. Answer the following question/

- i) Who went to see Rabbit?
 ii) What was Rabbit searching for?
 iii) Who lost the whistle?
 iv) Where was the whistle hiding?

Q10. Draw the picture of a “Rabbit and a Piglet”

Q11. Who said? Write the name against the sentence.

Example – “Come in!” _____ Rabbit.

- i) I’ve lost my whistle _____
- ii) I’ll help you look for it _____
- iii) Brother ! I can’t find it anywhere _____
- iv) “What a mess”! _____
- v) “Let’s have some tea” _____

Q12. Match the following words in the first form of the verbs to the second form

Example go went

1	See	Told	2	Call	Said
3	Push	Fell	4	Try	Opened
5	Open	Tried	6	Fall	Pushed
7	Say	Called	8	Tell	saw

Q13. Match the punctuation.

Example Comma ,

Full stop	‘ ‘
Duble inverted comma	-
Question mark	!
Exclamation mark	?
Dash	“ “
Single inverted comma	.

Q14. Match the words in column A with their opposite words

A	B
Go	First
After	Out
In	Close
Open	Before
Last	Come
Up	Few
All	Down
Hard	Lost
Find	Soft

F
K
M

p
m
sm

h
c
s

c
m
h

s
b
t



Lesson - 3

Hand Care

Q1. Trace a picture of the back side of your hand.

Q2. Trace a picture of the front side of your hand.

Q3. Fill up the blanks with the correct word-

- i) Wash your hands with _____ (soap / sugar)
- ii) Wash your hands before _____ (eating / sleeping)
- iii) Dirty hand carry _____ (gems / germs)
- iv) Hands should be washed with _____ water. (dirty / clean)
- v) _____ should be cut regularly (nails / fingers)

Q4. Fill in the blanks with appropriate words

Cleanser, fingers, water, palm, thumb

- i) Rub hands thoroughly with _____
- ii) Take one measure of _____
- iii) Rub hands _____ to palm.
- iv) Rotate right hand around left _____
- v) _____ linked in palms.

Q5. Write the meanings in Hindi.

Infection, control, rotate, palm, corner, stone

Q6. Write the words related to "Hand Care" in the bubbles

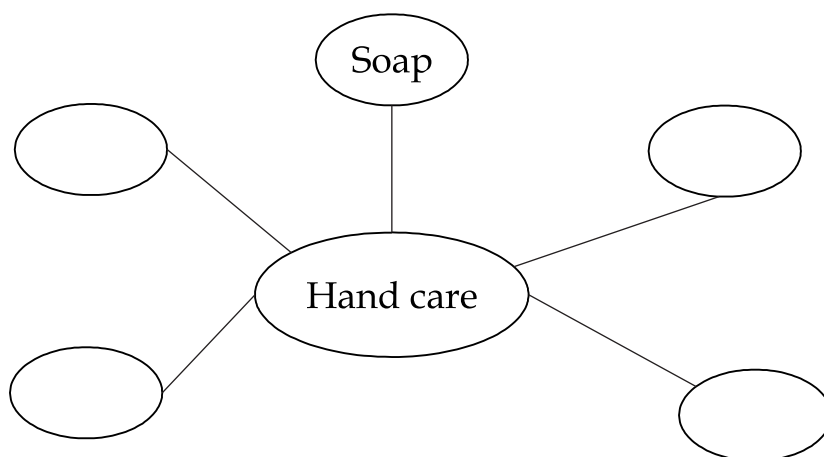

Q7. Write a "slogan" which shows "Hand care" is very important.

Q8. Complete the flow chart.

How to wash hand?

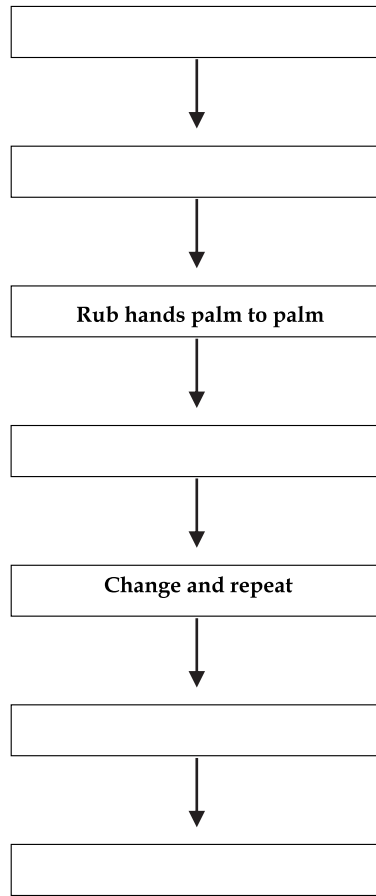

Q10. Insert a, e, i, o, u and complete the word

W__sh__ng

tr___n

M__ss__d

t__d__

H___s__

l_nch

Dr__w__r

d__ _r

L__k__ _g

sw__m



Lesson - 4

Hard to Believe

Q1. Match the column

- | | |
|-------------------------|---------------------|
| i) Francesco Lentini | eating its own eggs |
| ii) Lin | steal bananas |
| iii) Mud mania festival | soccer player |
| iv) Elephant | repeating the name |
| v) Parrot | Scottsdale, Arizona |
| vi) Hen | Magnetic man |

Q2. Answer the following questions in one word.

- i) Who was a soccer player?
- ii) Who was the magnet man?
- iii) To whom mummy handed a booklet?
- iv) How many presentations were put on the school display board?
- v) Which month the mud-mania festival is organized?

Q3. Tick the correct answer.

- i) Mummy handed to Monty _____
(a) Puzzle (b) a booklet
- ii) Monty's gift was a -
(a) poems (b) a book of interesting facts
- iii) The mud - mania festival is organized in the month of -
(a) June (b) July
- iv) Elephants stuff their _____ with mud
(a) eggs (b) grains (c) bells
- v) Who is the magnet man?
(a) Chentine (b) Lin

Q4. Fill up the blanks with the given words.

Identify, repeating, brought, stolen, witness

A _____ parrot was _____ to the court as a _____ in New Delhi.
It could _____ its real owner by _____ the names of her children.

Q5. Write true/false.

- i) Mummy handed a puzzle to Monty.

- ii) Monty's gift was a book of interesting facts.
- iii) Two presentations were on the school display board.
- iv) The Mud-mania festival is organized in the month of July.
- v) Elephant stuff their trunks with mud.

Q6. Match the two columns to make compound words.

Column - I	column- II
i) Mud	powder
ii) Forty	filled
iii) Display	seven
iv) Railway	station
v) Detergent	board

Column - I	column- II
i) Head	legged
ii) Cassette	field
iii) Quiz	mistress
iv) Magnetic	contest
v) Three	player

Q7. What does the word 'winged' stand for?

Q8. Complete the information asked in the table, one of them is done for you.

S.No	Who	What (festival went)	Where (place)
1	Elephants	Stealing banana	Myanmar
2	_____	Three lags	Sicily
3	Lin	_____	Gunung

Q9. What were victories?

Q10. Match the two columns to make compound words.

Column-I	Column-II
i) Bus	belt
ii) Copy	camp
iii) Photo	stop
iv) Tie	pen
v) Table	frame

Q11. Complete the following information

- i) 1960 - 1969 = 1960s
- ii) 1990 - 1999 =

iii) 1950 - ____ = 1950s

iv) 1880 - 1889 = ____

v) 1840 - ____ = ____

Q12. Fill in the blanks from the given words.

Slunged, stuffed, rescued, steal,, dangled, stick

i) He always threw the keys to me from a distance. ii) No one had seen Bittu taking out sweets from the kitchen. iii) The fire man saved two children from the top story of the building on fire. iv) It was easy to snatch at the chain of the watch that hanged out from grandpa's pocket v) Do not paste advertisements on the walls of the school building. **Q13. Answer the following questions.**

i) What were the victories?

ii) What is miraculous in them?

iii) Write three lines about the mud mania festival.

Q14. Write five lines about any person of your area who has some special qualities.**Q15. Write five lines about any local festival of your area.****Q16. Write the name of five persons of your local area who has some special qualities.**

Lesson - 5

Alice in wonderland-II

Q1. Put a cross (x) mark against the statements which are not true about Alice.

- i) Alice did not eat the cake. (_____)
- ii) When Alice ate the cake, she grew taller. (_____)
- iii) The door of the room was too small for Alice to get out. (_____)
- iv) Alice talked to the white rabbit and he helped her. (_____)
- v) There was a pool in the hall. (_____)
- vi) The white rabbit was going to give the fan and gloves to Alice. (_____)
- vii) Rabbit was dressed up to go somewhere. (_____)

Q2. Write the meanings in Hindi

Next, happy, enough, unlock, floor, wept, tears, entered, frightened, eaglet.

Q3. Match the following.

- | | |
|------------------|-------------------|
| i) Alice ate | taller |
| ii) Alice | the cake |
| iii) Alice | wept bitterly |
| iv) White rabbit | also swimming |
| v) A mouse was | was so frightened |

Q4. Give the opposite word

Tall, poor, happy, find, wet, down

Q5. Give the second form of verb for the following words

Example: find - found

- | | |
|---------------------|-----------------------|
| i) Sit - _____ | ii) grow - _____ |
| iii) can - _____ | iv) weep - _____ |
| v) run - _____ | vi) enter - _____ |
| vii) dress - _____ | viii) request - _____ |
| ix) fright - _____ | x) drop - _____ |
| xi) happen - _____ | xii) hear - _____ |
| xiii) think - _____ | |

Q6. Re-arrange the letters and write the correct word.

- | | |
|----------------------|-------------------|
| i) Pctuire - picture | |
| ii) Tinhk - _____ | iii) taer - _____ |

- iv) child - _____ v) rquese - _____
vi) rabbit - _____

Q7. Add 'ly' to the given words.

Example- Rare + ly = Rarely

- i) Bitter + _____ = _____
ii) sudden + _____ = _____
iii) love + _____ = _____
iv) beautiful + _____ = _____
v) slow + _____ = _____

Q8. Write the names of all those who were swimming in the pool of tears?

Q9. What was written on the cake?

Q10. What happened to Alice when she ate the cake?

Q11. Who entered the room suddenly?

Q12. Complete the table to tell what Alice could do in the Wonder land and what she could not. Select the phrases from the list given below.

unlock the door, look through the door outside, lie on the floor, touch the ceiling, swim in the pool of tears, get through the door out, grow tall, get smaller

Could	Could not
Eat the cake	Get through the door

Q13. Look at the given example and fill up the blank space.

Tall	Taller	Tallest
Long		Longest
	Larger	Largest
Small	Smaller	
	Shorter	Shortest
Cool		coolest

Q15. Add 'ing' to the following words as given in the example-

Example- hop = hopping

i) Swim = _____

ii) Run = _____

iii) scan = _____

iv) trap = _____

v) flap = _____

vi) cut = _____

vii) set = _____

viii) net = _____

Q16. State 'true' or 'false'.

- i) Alice found a little cake.
- ii) "DRINK ME" was written on the cake.
- iii) Rabbit was dressed up to go somewhere.
- iv) Alice was just about the size of a mouse.
- v) In the pool of tears a cat was swimming.

Q17. Fill in the blanks with the missing letters.

i) C_ _ling

ii) Re_ch

iii) M_na_e

iv) _arge

v) Entr_

Q18. Find the words from the box that can complete the sentences correctly.

Drankup, grownup, ateup, tornup, wakeup

- i) Montu was naughty when he was a boy. He is a smart and _____ person now.
- ii) Meenu was very sad to find her drawing book _____ when she came home.
- iii) I always _____ at 5 in the morning.
- iv) Ahmed's mother was happy because he _____ all the milk.
- v) I was very hungry and _____ all the biscuits in the kitchen.

Q19. Write down the name of the things that you use daily.

Q20. Write ten lines about your Mother.

Q21. Draw picture of Rabbit.



Lesson - 6

Unity is Strength

Q1. Fill in the blanks with the words given.

Doves, club, tired, net, mouse

- i) The smallest dove was so _____
- ii) A flock of _____ went in search of food.
- iii) Suddenly a vast _____ fell over them.
- iv) The hunter was carrying a huge _____
- v) The little _____ was wise.

Q2. Write the meanings in Hindi.

Search, dove, scattered, hunter, unity,
strength, Faith, mouse, flapping, chase, club

Q3. Make plural form of the following words

- i) Mile - _____
- ii) Friend - _____
- iii) Dove - _____
- iv) Hill - _____
- v) Valley - _____
- vi) Tooth - _____

Q4. Tick the correct option

- i) The smallest of the doves was-

(a) tired	(b) happy
(b) sad	(c) busy
- ii) The _____ flapped his wings harder.

(a) King dove	(c) little dove
(b) Hunter	(d) mouse
- iii) The _____ was carrying a huge club.

(a) King	(c) dove
(b) Hunter	(d) crow
- iv) All the doves were _____ to get out of net.

(a) Fighting	(c) singing
(b) running	(d) struggling

- v) Soon they reached the place where the _____
 (a) Hunter lived (c) mouse lived
 (b) Dove lived (d) king lived

Q5. Make two words starting with the following letters.

Example- E = Egg, Elephant

- i) D = _____, _____
 ii) S = _____, _____
 iii) T = _____, _____
 iv) M = _____, _____
 v) A = _____, _____

Q6. Write the second form of verb of the following words

Example- fly = flew

- | | |
|--------------------|------------------------|
| i) Rise = _____ | ii) understand = _____ |
| iii) say = _____ | iv) catch = _____ |
| v) call = _____ | vi) hear = _____ |
| vii) reach = _____ | viii) find = _____ |
| ix) turn = _____ | x) look = _____ |

Q7. Answer the following questions

- i) Who went in search of food?
 ii) Who felt tired?
 iii) Who cut the net with his teeth?
 iv) Who had an idea?

Q8. Complete the table-

s.no	Questions	Who said it?
Example	"We are caught. What shall we do now?"	King dove
1	"How can we save ourselves?"	
2	"no, no please free my followers first"	
3	"ok king, please can we rest a bit"	
4	" I have an idea.... we shall all fly up, carrying the net with us....."	
5	"Very well. I, shell set you free first."	

Lesson - 7

Jimmy Jet and His TV Set

Q.1 Fill in the blanks (much, story watch, know ture)

I tell you the _____ of jummy jet and you _____ what I tell you is _____ he loved to _____ his TV set almost as _____ as you.

Q.2 Choose the correct word from the bracket

- i) He watched _____ day . (whole, all)
- ii) He watched all _____. (night, day)
- iii) And all the _____ between. (Games, Shows)
- iv) He watched till his _____ (knees, eyes) were frozen wide.
- v) And his bottom grew into his _____ (Table, chair)

Q.3 Match the following.

A	B
Chin	TV Screen
brains	knobs
face	TV table
ears	tuning dial.

Q.4 Match the following.

A	B
Hair	knob
bottom	antennae
brains	TV Screen
face	chair
ears	TV tubes

Q.5 Complete the word verb

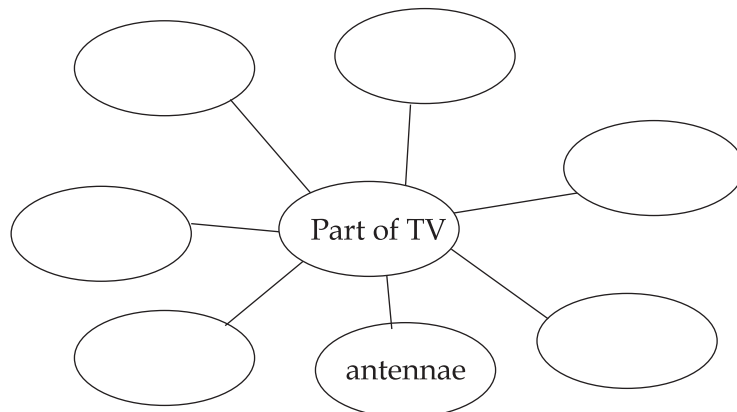

Q.6 Circle the odd one

- i) see, bee, knee, (tob) example ii) Pea, tea, see, sea
 iii) Tell, tail, pail, sail iv) Mayre, hair, Pair, chair
 v) Ice, pie, dice, spice i) Cell, Fail, Bell, Tell

Q.7 Encircle your favourite T.V. channels.

Pogo, National Geographics, Zee TV., Sanskar, Cartoon Network, Aaj Tak, Doordarshan, Discovery, D.D. News

Q.8 Short Answers the following question

- i) What did jimmy jet want to do?
 ii) Why did jim grow pole and lean?
 iii) What looked like a tail ?
 iv) What turned into T.V. Tubes?
 v) What grew out of his hair?
 vi) What turned into a tuning dial?
 vii) What grew into his chair?
 viii) What tuned into a TV Screen?
 ix) What grew instead of his ears.
 x) Did you enjoy the poem?

Q.9 Long Answer (application)

- a) What message does this poem convey?
 b) Writer two-two rhyming words of the following words.
 i) Lean ii) Jet iii) Hair iv) Pale v) Pin
 c) Complete the word grid.

Find the rhyming words for the words given below

- i) Tea ii) Pet iii) Sail iv) Go v) Hair

S	S	O	J	E	Y	J	A	I	L
E	C	H	A	I	R		S	E	T
A	D	H	P	A	I	R	B	O	W
G	Z	N	A	I	L	F	A	I	L
Q	X	B	E	T	F	A	I	R	Q
P	E	A	O	O	M	E	T	K	R

b) Complete the word verb.

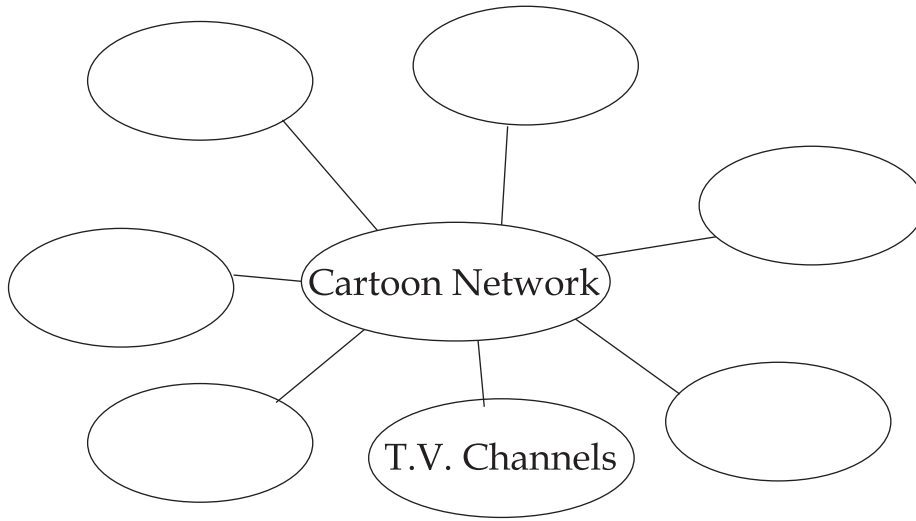

Assignments

i) Draw the picture of jimmy jet.

Project Work

i) Collect at least two funny poems from any magazine or news paper.



Lesson - 8

A Serious Talk

Q1. Match the opposite words

- | | |
|--------------|---------|
| i) Beautiful | dirty |
| ii) Come | old |
| iii) Clean | present |
| iv) Past | go |
| v) New | ugly |

Q2. Write the meaning of given words in Hindi.

Before, Past, Walk, Spider, Rotten, Feelings, Lunch, Again, Garbage, Web

Q3. Fill in the blanks with appropriate words.

Swing, see, hear, honey, take off

- i) There is a _____ in the web again.
- ii) I would like to drink _____ like butterflies.
- iii) It's so nice to _____ you.
- iv) I can't _____ anyone.
- v) The fly was ready to _____.

Q5. Write true or false.

- i) Spider makes web.
- ii) Spider eats flies.
- iii) Flies eat fruits
- iv) Birds are reptiles.
- v) Spider and flies were a friend.

Q6. Use numbers to put sentences in the order in which the events they happened.

- i) A fly was caught in a cobweb.
- ii) The spider asked for help.
- iii) A spider sat quietly in the center of its web.
- iv) The spider was inside the tube of the vacuum cleaner.
- v) The spider thought she was going to die.

Q7. Match the following as rhyming words.

Take off	talk
Spider	flew off
Spider web	rider
After	cleaner
Recover	better
Walk	cobweb

Q8. Separate the root word

i) Circling	= _____	ii) revolving	= _____
iii) spinning	= _____	iv) rotating	= _____
v) whirling	= _____	vi) winding	= _____

Q9. Use 'en' 'ne'

i) ___ _ d	ii) Op___
iii) Ho___y	iv) T___
v) Gre___	vi) Wh___
vii) Clea ___ r	

Q10. Write the action words with 's'

i) Fly	ii) Give	iii) Insect	iv) Plate
v) Hop	vi) Leg	vii) Heap	viii) Bite
ix) Cry			

Q11. Write the names of their homes.

i) Birds	ii) Spider	
iii) Snake	iv) Fish	v) Honeybee

Q12. Write the opposites of given words

i) Hand	ii) Open	iii) Wake
iv) Grandma	v) Finish	vi) Win
vii) Day	viii) Girl	

Q13. Combine the other part as given below.

Example: If I had legs (run away from the saucer.)

If I had legs, I would run away from the saucer.

- If I had a straw (drink the water)
- If I had roller skates (win every race)
- If I had wings (invite uncle fox for a race)

- iv) If I had a stool (eat all the grapes)
v) If I could open the lid of the jar (finish all the sugar in he jar)

Assignment-

- Write names of insects that can be trapped in the spider's web. Clues are given below-
 - A three letter name and is very small.
 - It is green in colour, hops in fields.
 - It bites you at night.
 - It lives in the honey hives.
 - Sachintendulkar's game.
- Write the name of days in a week.
- Write about insects that you see in your surrounding.

i) Name of insect	ii) Total types
iii) Shape of Body	iv) Number of Legs
v) shape of legs	vi) Number of Wings- number, shapes
vii) Shape of wings	vii) Mouth parts- shape
viii) Mouth used for	viii) Likings
- No one likes flies. If the fly want to become good insect, what would you suggest him todo. Write a small letter to him you can take help from the lesson.

Scrap book-

- Collect pictures of animals, birds, and insects and paste them in front of each other. Also write their names.
- Collect pictures of different types of flies and paste it, colour it.

Portfolio

- Draw picture of a web.
- Draw the picture of a clock.
- Draw the picture of a ball.
- Draw the picture of honey bee.



Lesson - 9

Have a Nice cup of Tea

Q1. Tick the correct answer

- i) The lesson is in the form of an autobiography because it is about.
- (a) The tea
 - (b) The shrub that talks about itself
 - (c) A place
 - (d) A county
- ii) The beverage (Tea) is made from
- (a) Young shoots on leaves
 - (b) Young roots
 - (c) The fruits
 - (d) The seeds
- iii) Tea is an _____ shrub
- (a) Every time
 - (b) Ever green
 - (c) Ever lasting
 - (d) Every day
- iv) The young shoots and leaves are picked every _____ years.
- (a) Two years
 - (b) Four years
 - (c) Five years
 - (d) Six years
- v) I am a tea _____ from the garden of kerala.
- (a) Plant
 - (b) Tree
 - (c) Shrub
 - (d) Root

Q2 Complete the flow chart to show how you make tea. Arrange the phrases in the box

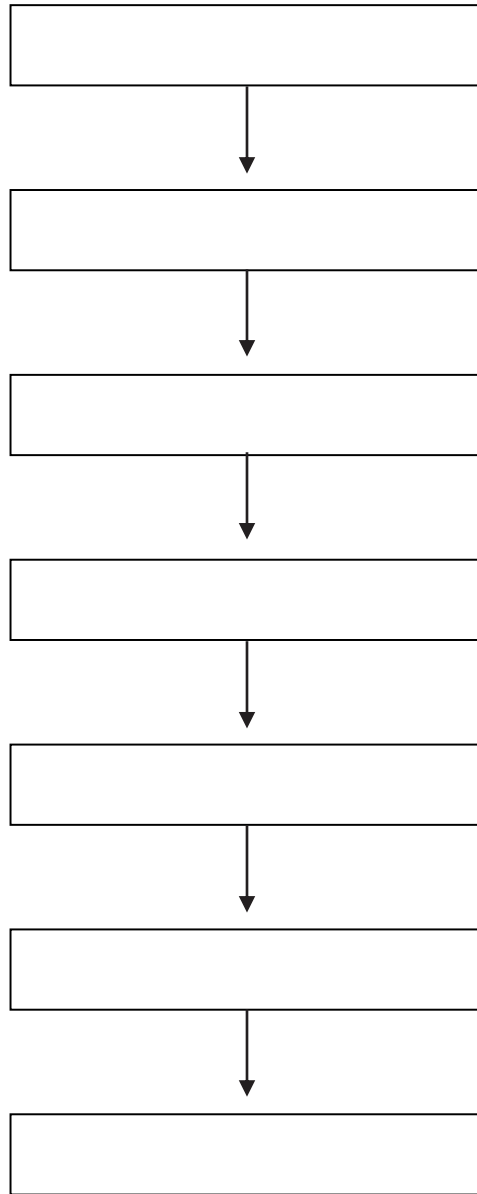

- (a) Put the bowl on the stove
- (b) Take a bowl with some water in it.
- (c) Add tea leaves
- (d) Add sugar.
- (e) Add milk
- (f) Filter in a cup
- (g) Leave the mixture to back

Q3. Imagine yourself as the tea shrub given in the passage and fill the bio data.

Bio data

- (a) Name
- (b) Address
- (c) Age
- (d) Weight
- (e) Characteristics

Q4. Complete the following webs by adding more words related to tea

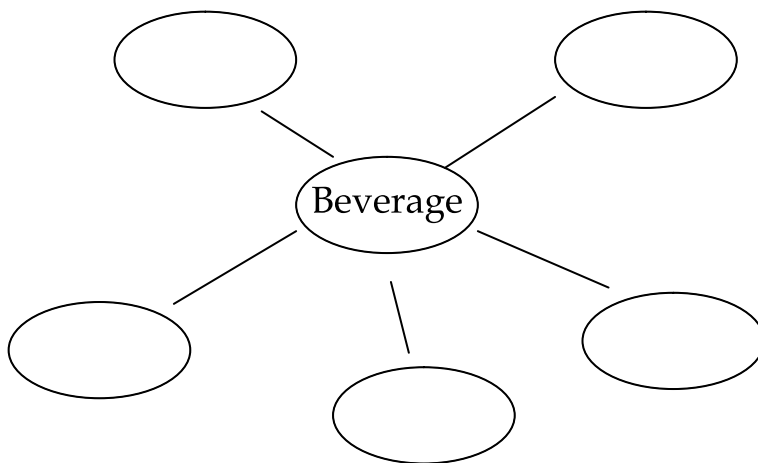
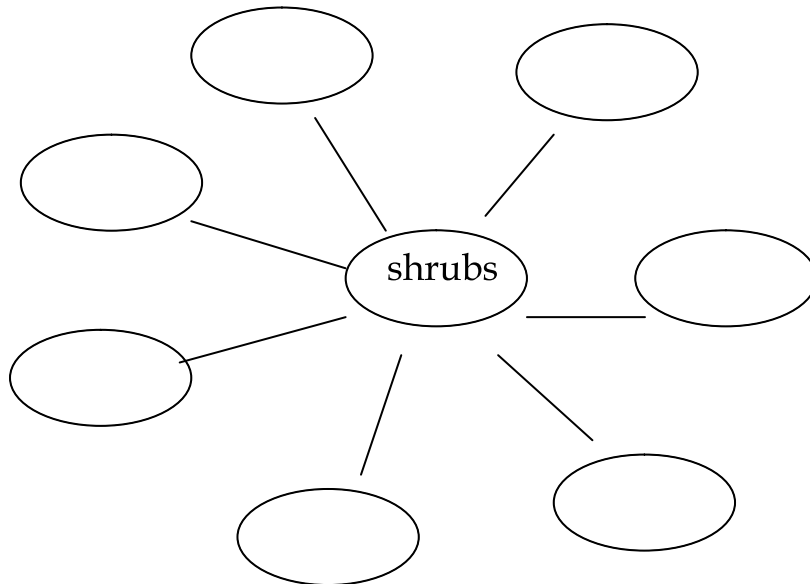

Q 5. Given are some clues in the block. Use these clues to form sentences. Use who for persons, where for places and which/that for things.

Example- cobbler: mends shoes
 Hospital: ill or wounded people are treated
 Pen- stand: used for keeping pens.

- (a) A person who mends shoes is a cobbler.
 (b) A place where ill or wounded people are treated is a hospital.
 (c) A thing or container which is used to keep pens is a pen stand.

- i) Carpenter: makes and repairs wooden objects
 ii) Bottle: used for carrying drinking water.
 iii) Post office: stamps are brought, letters and parcels are sent
 iv) Tiffin box: used for keeping light meal (snacks)
 v) Police station: a local office of police in a town or city where complaints can be made.
 vi) Bus stand: buses stop for passengers to get in or out.
 vii) Bag: used for keeping things.
 viii) Doctor: trained to treat people while they are ill.
 ix) Cup: used to drink tea, coffee, milk etc.

Q6. Given are some pictures write an autobiography imagining yourself to be one in the picture and write a small paragraph using the clues given in the box. The first is done for you.

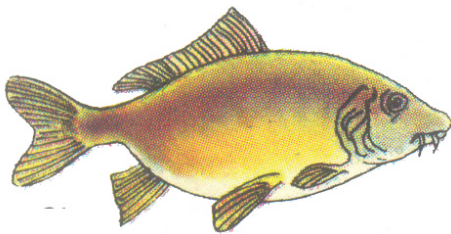

Clues: fins, can swim, gills, breathe through, gives, different colours, sometimes, scales too.

I am a fish. I have fins and can swim. I have a tail. I breathe through my gills. I have scales too. I have different colours on my body.

(i)

Crab



Hard shells, eight legs, two claws, move sideways, not straight, catch food with claws

(ii)

Octopus



Eight tentacles, catch food, rounded body, soft, smaller, creatures for food

(iii)

Shark

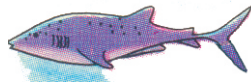

Biggest and most powerful fish, lives in sea , can eat human beings.

Q7. Read the passage and fill in the blanks and give answer of questions given below-

In the class of 100 students, 70 like tea, 5 like milk, 10 like coffee and 15 like lassi.

Out of 60 girls students 40 like tea, 5 like coffee, 10 like lassi and 5 like milk.

	Students	Girls	Boys
Tea			
Milk			
Coffee			
Lassi			
total			

- i) How many girls are there in the class?
- ii) How many boy are there in the class?

Q 8. Read the riddles and find out the correct words.

(i)

I am a five letter word
I am shorter than a tree
I have rub in me
I rhyme with tub
What word am I?

(ii)

I am a seven letter word
I rhyme with follow
I mean 'not deep'
I end with low
What word am I?

(iii)

I am an eleven letter word
My suffix is.....'tion'
I start with 'sti'
I have the power to make one active
What word am I?

(iv)

I mean 'bring to rest'
I am a six letter word
I start with 'set'
What word am I?

(v)

I am a five letter word
My suffix is 'tion'
I am synonymous of country
I start with 'N'
What word am I?

Q9. Write the meanings in Hindi.

famous, infuse, grow, wild, shoot, pick, spread,
 delicate, innocent, alert, prepare, violent, dispute,
 deduce, stimulate, serve, hope, shake

Q10. Make new word

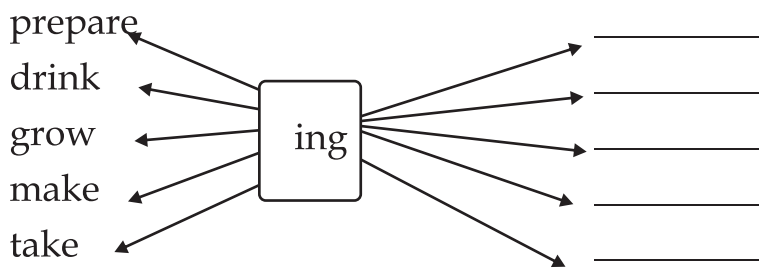
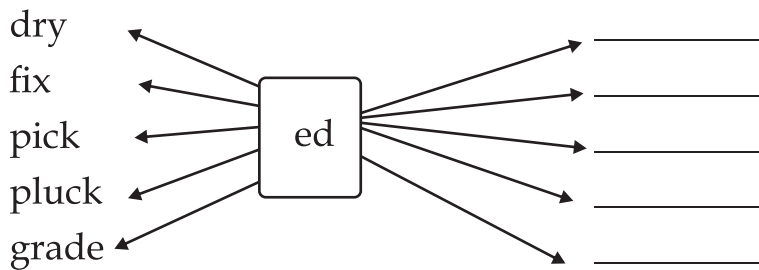
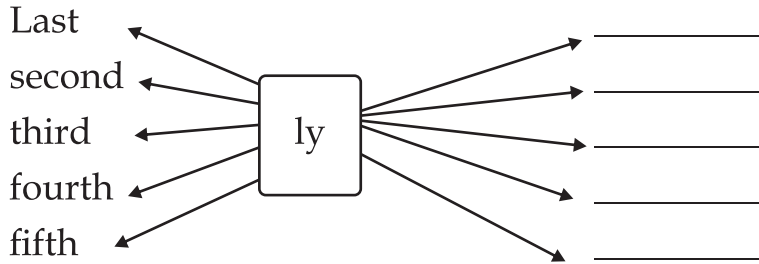

Assignment-

Write your views about the beverage (tea).

Scrap book-

Draw or past the picture of cup of tea, tea shrub.

Portfolio

Draw a picture of fish, octopus.



Lesson - 10

Our Little River

Q1. Complete the poem

Our little river _____ and _____
 It's just knee-deep when _____
 How easy _____
 Cattle and carts _____
 The _____ slope _____, though thujre _____
 And in the summer _____

Q2. Match the opposite words

Wet	town
Here	yes
Golden	dry
No	there
Village	silver

Q3. Make new words

Cheer	←	ful	→	_____
Joy	←	ful	→	_____
Wonder	←	ful	→	_____
House	←	ful	→	_____
Care	←	ful	→	_____

Q4. Answer the following questions-

- i) How is the river?
- ii) How do the river banks look like in summer?
- iii) On which side of the river are the village houses situated?
- iv) In which season does the river fill up to brim?
- v) In which season we wear raincoat?
- vi) How does the river water look?

Q5. Write missing letters.

- | | | |
|---------------|----------|------------|
| i) V_ll_g_ | ii) E_sy | iii) W_m_m |
| iv) H_m_w_r_d | v) cl_th | vi) sm_ll |
| vii) c_urs_ | | |

Q6. Fill in the blanks with 's'

- | | |
|------------|------------|
| i) _pot | ii) pot_ |
| iii) bit_ | iv) _plash |
| v) _and | vi) turn_ |
| vii) _crub | viii) pan_ |
| ix) whirl_ | x) _tand_ |

Q7. Write the meaning of given words in Hindi.

begin, turn, burn, high, scrub, festival, wood, rain, rush, cattle, cross, fill, duck, silence

Q8. Tick against the right one and cross against the wrong one.

- i) Fish swims in the river.
- ii) The river is straight.
- iii) The river is dirty.
- iv) The village houses stand arranged.
- v) Children play in the river.
- vi) It is easy to cross the river in summer.

Q9. Add 'ood' and make new word

- i) F + ood = food
- ii) M + _____ = _____
- iii) W + _____ = _____
- iv) G + _____ = _____
- v) H + _____ = _____

Q11. Underline the nouns in the sentences given below.

- i) Cattle and carts just move across.
- ii) Ramu lives in a village.
- iii) There are many mangoes in a bucket.
- iv) The river fills upto the brim.
- v) The flowers are white in colour.

Portfolio

- Draw the picture of rainy season.
- Draw the picture of different flowers and colour it.
- Draw the picture of river with trees.
- Draw the picture of trees in summer season.

- Draw the picture of farmer ploughing field.
- Children play in the river.

Scrap book

- Make varieties of paper boats.
- Collects some pictures of flowers, seasons and stick it.

Assignment-

- Write the names of months in a year.
- Write the names of different types of festivals.
- Write the names of seasons.



Lesson - 11

Grand Children by Surprise

Q1. Answer the following questions-

- i) How was the address on the letter different from the address of the Newton's?
- ii) Do you find anything funny in the advertising put in the newspaper? If yes, what is it?
- iii) What did the grandchildren play with?
- iv) Did the children enjoy the time they spent with the grand parents?
- v) Even the clock went "tock-tick"
 - (a) How do clocks go?
 - (b) Why does the writer say that the clock went tock-tick?
- vi) Name the things that the Newtons gave to the children?
- vii) How was Mr. Newton?
- viii) What made by Mr. Newton and how it look like?
- ix) What did Mr. Newton know about the children?
- x) How was Mr and Mrs. Newton's house?

Q2. Look at the flow chart carefully. You will know the paper is made. Use is/are + verb third form of the words given in the brackets and put them in the boxes. An example is given for you.

Example- Paper is made from trees. (make)



At first the trees off their bark. (strip)



Then they to a pulp. (grind)



Then the pulp with chemicals. (cook)



Then it with water. (wash)



Then it .(bleach)



Then it . (beat)
↓

Then it with water. (mix)
↓

Then it into one end of a paper making machine. (feed)

Q3. Pick out the words from the box and complete the statements given below.

Neat pin, cold ice, black coal, hot fire, white milk, blue sky, red blood

- i) The room was as _____.
- ii) His hand were as _____.
- iii) The bettle is as _____.
- iv) Her teeth are as _____.
- v) The water looks as _____.
- vi) The colour of this rose is as _____.

Q4. Make new word

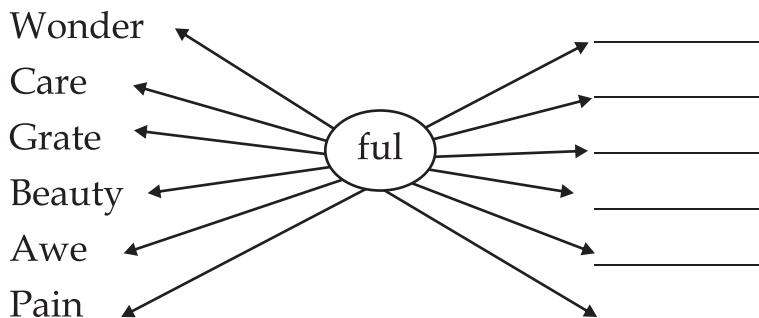
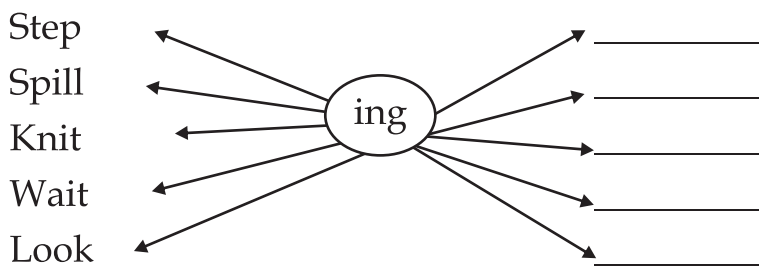
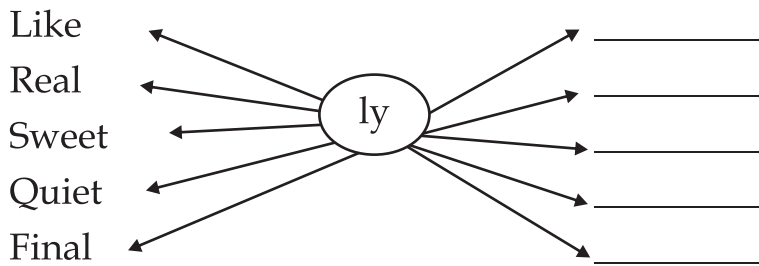

Q5. Match the column

- | | |
|------------|-------|
| i) Short | fat |
| ii) Big | after |
| iii) Thin | sad |
| iv) Before | long |
| v) Happy | small |

Q6. Write the meanings in Hindi

Mess, neat, make, somebody, away, busy, borrow, happy, glad, really, little, enough, everybody, back, fly

Q7. Make a list of your classmates who are afraid of the following insects, animals etc.

Insects/animals	Name of students
A rat	
A frog	
A dog	
A cockroach	
A lizard	
A snake	
A spider	
An ant	
A mosquito	

Q8. Write the missing letters.

- i) E_o_gh = _____
 ii) C_i_d_en = _____
 iii) S_t_r_ay = _____
 iv) E_e_y_h_ng = _____
 v) T_g_t_er = _____

Q9. Rearrange the letters

- i) sbemodoy = _____
 ii) kconk = _____
 iii) funny = _____
 iv) aewsnr = _____
 v) mdnaoy = _____

Assignment-

- Write a notice for a news paper about a dog you have lost. Take the help of the words given below.
- Fat, white, black eyes, with red collar, long tail

Scrap book

- Draw or paste the picture of truck, train, doll

Portfolio

- Draw a picture of motorcycle.



Lesson - 12

The Chinese – Our Neighbour

Q1. Write one word for following.

- i) Who walks on a rope.
- ii) Who plays music.
- iii) Who lifts the weight.
- iv) Who dances.
- v) Who do funny things to make us happy.
- vi) Who shows magic.

Q2. Answer the following questions

- i) Who walked along the river?
- ii) Write the name of the two rivers mentioned in the lesson?
- iii) Who built the great wall?
- iv) What shows were going on in the fair?
- v) Did Chang buy anything from the stalls?
- vi) Why was Chang happy?
- vii) Where was the Chang passing through?
- viii) What did Chang want to be?
- ix) What was happening in Loyang?

Q3. Write the meanings of given words in Hindi.

Calculation, acrobat, wrestlers, exciting, selling, utensil, recent, fertile, increase, plough, trader, cheap, huge, buzz, sight

Q4. Add 'ion' and make new word

Verb	Noun
Calculate	
Formulate	
Celebrate	
Locate	
Participate	
Narrate	
Invite	
Operate	
Dictate	

Q5. Tick ✓ correct sentences.

- i) Chang lives in our age.
- ii) The rich people in their silk dresses and shoes.
- iii) Chang lived before the invention of silk.
- iv) Chang lived during the age when paper was invented.
- v) Chang lived before the invention of paper.

Q6. Add 'ing' and make new words.

- | | | | |
|-----------|-------|----------|-------|
| i) Buzz | _____ | ii) Writ | _____ |
| iii) Pass | _____ | iv) Lift | _____ |
| v) Excit | _____ | | |

Q7. Write the missing letters

- | | | |
|------------|-------------|-------------|
| i) Sp___d | ii) Sh_rt | iii) Furr_w |
| iv) Dr_g_n | v) B_ref__t | vi) J_ggl_r |

Q8. Write true or false against the statement.

Chang was a part of this wonderful great civilization.

- i) It was the festival of harvest.
- ii) It was the festival of lights.
- iii) It was the festival of new year.
- iv) It was the festival of horse race.
- v) It was the festival of kite flying.
- vi) It was the festival of lanterns.

Q9. Match the following

- | | |
|----------------|--|
| i) Mathematics | the study of past events |
| ii) Civics | scientific study of stars and plants |
| iii) Geography | 1,2,3,4 |
| iv) Astrology | the study of government and its business |
| v) Botany | study of plants |
| vi) History | description of the earth |

Q10 Choose the correct answer.

- i) The great wall of China is

(a) 2500 km long	(b) 2700 km long
(b) 2300 km long	(d) 2400 km long

ii) The wall is stretched along the river

(a) Lo

(c) yellow river

(b) Huang Ho

(d) Si-kiong

Q 11. Write the phrases using ed, en, ing

i) Boil - rice

Earth - pots

Fly - kite

(_____)

(_____)

(_____)

ii) Increase - price

Wood - furniture

Talk - bird

(_____)

(_____)

(_____)

iii) Cook - food

Gold - ring

Weep - child

(_____)

(_____)

(_____)

iv) Colour - picture

Rat - apple

Love - mother

(_____)

(_____)

(_____)

Q 12. Fill in the blanks with who, when and where

i) _____ are you going?

ii) _____ are you?

iii) _____ is your examination?

iv) _____ is your home?

v) _____ is your class teacher?

vi) _____ will you coming back to class room?

Q 13. Fill in the blanks using the words given below-

Carried, dussehra, baster, dance, worship, decorated

i) Maa Danteshwari's temple is _____ for the festival of _____

ii) Maa Danteshwari's Rath is _____ on this day.

iii) People from all over Chhattisgarh visit _____ to _____ Maa Danteshwari

iv) The people of Bastar wear new clothes and _____ in groups.

Q 14. Match the following

i) Carnival

celebrated in March

ii) Snow festival

celebrated in April

iii) Saonkran

celebrated in Brazil

iv) Holi

celebrated in February

Q15. Match the following inventions with persons and place.

Invention	Place	Person
Printing press	USA	James watt
Thermometer	USA	Elias Howe
Steam engine	Germany	Johannes Guttenberg
Type Writer	USA	Galileo Galilee
Sewing machine	Britain	Howard Aiken
Telephone	Britain	John Logic Baird
Television	USA	Christopher Scholes
Digital	Italy	Alexander Graham Bell

Assignment-

1. Complete the table

S.No	Festival	Country	Month	Special
1		Japan		
2			February	
3				People play with colour
4			April	

2. Write about the festival Holi in your own words.

Portfolio

- Collect pictures of these festivals Holi, carnival, Snow festival



Lesson - 13

Only God can Make a Tree

Q1. Put ✓ mark on the correct alternatives

- i) Who is 'I' in the poem?
 - (a) Tree
 - (b) Woman
 - (c) poet
 - (d) bird
- ii) The tree is like-
 - (a) A mother
 - (b) A child
 - (c) God
 - (d) the earth
- iii) The tree is fed by
 - (a) Another tree
 - (b) Mother Earth
 - (c) the Robin
 - (d) God
- iv) The earth in the poem is compared to
 - (a) God
 - (b) A little girl
 - (c) a tree
 - (d) a mother
- v) The hair of the tree is its
 - (a) Stem
 - (b) Flowers
 - (c) branches
 - (d) roots

Q2. Find out the rhyming pairs of the words

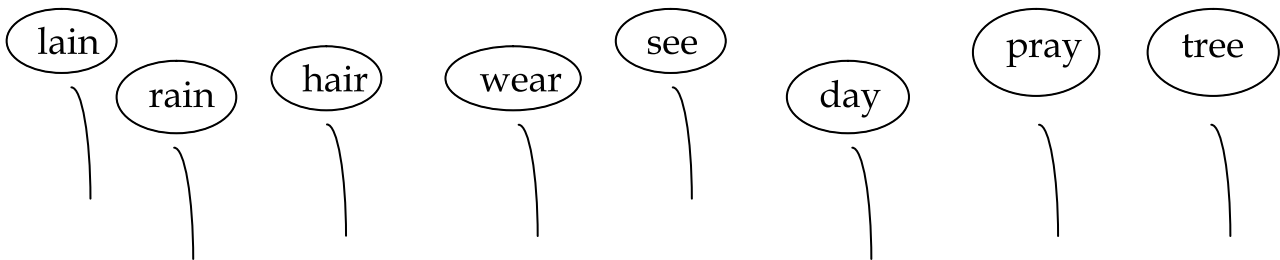

Q3. Answer the following questions

- i) What part of the tree is referred to as its mouth?
- ii) How can the tree lift its arms to pray?
- iii) Who lives intimately with the tree?
- iv) What does the tree get from the earth's sweet flowing breast?
- v) What lay in the bosom of the tree?
- vi) Who can make a tree?
- vii) Is the tree like mother?

Q4. Match the following according to the poem.

A small bird	intimate
Chest	prest
Pressed	lain
Very close	bosom
Spread	Robin

Q5. Write five lines about your favorite tree.

Q6 Write any five parts of any tree.

Q7. Match the rhyming words.

Rain	Bright
Day	Pay
Tree	tear
Light	Plain
Wear	Bee

Q8. Encircle the parts of the tree from the given word

Branch,	Day,	Fruit	Big,	Flower,
Ball	Leaf,	Pen,	Trunk	

Q9. Complete the given table

American Spelling	British spelling
Favor	Favour
Labour	
Valor	Valour
	Ramour
Harbor	

Q10. Complete the word web.

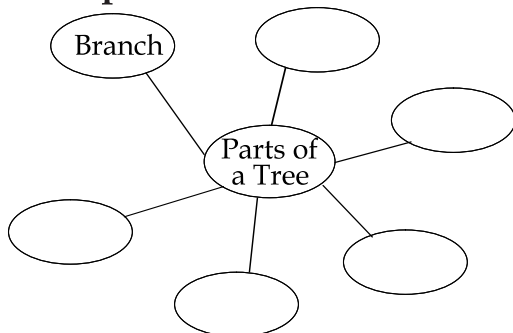

Q11. Find the parts of tree from the given puzzle

F	R	U	I	T	W
L	E	A	F	R	Q
O	Y	A	Z	U	T
W	T	E	P	N	K
E	Z	Y	V	K	Q
R	O	O	T	V	P

Q12. Tick ✓ the correct one

- | | |
|------------|------------|
| (a) Flower | (b) Flower |
| (a) Root | (b) Rut |
| (a) Trank | (b) Trunk |
| (a) Leaf | (b) Lef |
| (a) Fruit | (b) Frut |

Portfolio

- Draw the picture of a tree and label it.

Scrap book

- Collect leaves of different plants. Paste them on a herbarium file.



Lesson - 14

The Angel of Peace

Q1. Circle the odd one.

- i) All, Ball, Call, Fell
- ii) Rat, Net, Fat, Hat
- iii) Near, Layer, Bear, Tear,
- iv) Ill, Meal, Kill, Fill
- v) Way, Say, Lie, May

Q2. Make new words

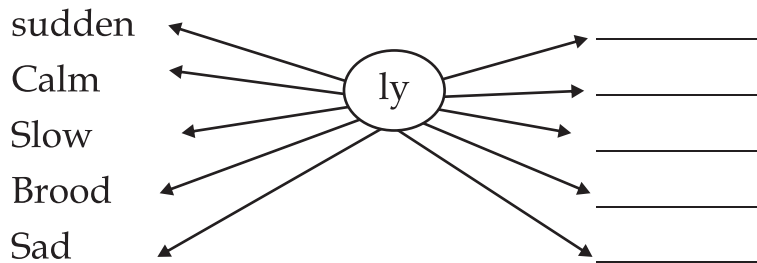
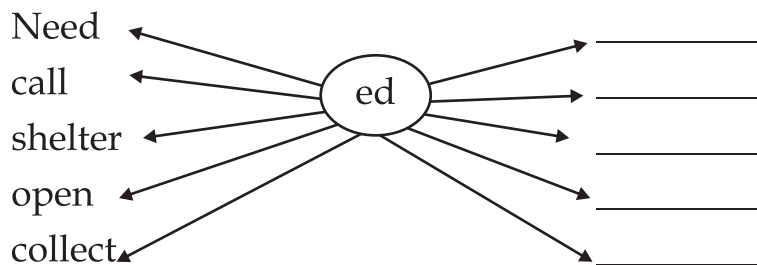

Q3. Answer the following question

- i) How was the atmosphere at the Christmas time?
- ii) Who arrange Christmas party every year for the children?
- iii) What is the other name of Mother Teresa?
- iv) What is 'Nirmal Hriday'?
- v) What did mother do on the street of Kolkata?
- vi) How was the 'Missionaries of Charity' formed?
- vii) What was mother Teresa's real wealth?
- viii) How do people remember mother Teresa?
- ix) What did the admirer say?

Q4. Write true or false for each of the sentences given below

- i) The children of charity home used to enjoy Christmas party every year. (____)
- ii) The envelop contained new thousand rupees notes. (____)
- iii) Many times the inmates of the charity home had no Christmas party. (____)
- iv) Mother knew from where the money would come for a project. (____)
- v) The municipal authorities refused to provide her a place for a poor. (____)
- vi) Most of the members of the Missionaries of charity are Indians. (____)
- vii) Mother Teresa knew the greatness of the poor. (____)

Q5. Find out the words from the puzzle which come from the clues given below the puzzle.

S	M	S	T	R	E	E	T	A	K
M	E	R	C	Y	D	J	G	P	C
S	H	C	L	T	E	R	P	U	H
B	C	T	P	K	S	P	O	T	A
S	L	U	M	S	T	I	M	T	R
D	O	K	C	E	I	S	A	E	I
W	Y	C	T	I	T	A	I	R	T
C	H	I	L	D	U	I	Z	C	Y
D	I	G	N	I	T	Y	E	C	K
P	O	O	R	G	E	T	N	T	P

Clues-

- i) Road
- ii) Suffering from illness
- iii) A place to live in
- iv) One who is not rich
- v) Kindness, pity
- vi) Ability to behave in a calm and respectable way
- vii) Son or daughter of a person
- viii) Having no money, no food and no shelter
- ix) A house or an area of a city that is in a very bad condition
- x) To collect money or things to help poor.

Q7. Put \checkmark and X mark according to the sentences.

- i) Mother Teresa called 'The Angel of Mercy'. (____)
- ii) Her first major project was a home for herself. (____)

iii) Municipal authorities provided a place near the Ram temple Kolkata.
(____)

iv) She lived a simple life, travelled by second class on train. (____)

v) The woman in the yellow sari with a white border, Mother Teresa. (____)

Q8. Complete the paragraph from the lesson.

Her real wealth was Himalayan in size 7500 children in 60 schools, _____ patients cared for in _____ dispensaries, victims of leprosy in _____ clinics, _____ abandoned or orphaned children in _____ homes and _____ destitute or dying people in _____ homes all this in _____ cities and towns in India and in a dozen other countries.

Q9. Form sentences using the following words.

Crisis, project, dignity, hygiene, starving, property, hungry

Q10. Write the meanings of the words in Hindi.

- | | |
|-----------------------|---------------------|
| i) Occasion | ii) Destitute |
| iii) refuse | iv) dignity |
| v) acceptable | vi) shelter |
| vii) assistance | viii) humour |
| ix) honesty | x) courage |

Q11. Rearrange the letters.

- | | |
|--------------------|---------------------|
| i) Tleponehe | ii) Cnerte |
| iii) Sureb | iv) Vimcit |
| v) Rerutn | vi) Rebmur |
| vii) Broefe | viii) lporpeu |

Q12. Match the columns

- | | |
|-----------------|---------|
| i) Near | far |
| ii) Able | many |
| iii) One | honest |
| iv) Open | night |
| v) Near | poor |
| vi) Dishonest | ever |
| vii) Discourage | unable |
| viii) Rich | agree |
| ix) Refuse | close |
| x) Day | courage |

Q13. Write the missing letters

- i) M_n_c_p_l =
- ii) W_e_e =
- iii) S_r_et =
- iv) P_o_e_t =
- v) G_t_er =
- vi) M_r_y =
- vii) C_i_is =
- viii) H_g_e_e =
- ix) C_i_ic =
- x) A_x_o_s =

Assignment-

Write the information about Mother Teresa.

- i) First name-
- ii) Her date of birth-
- iii) Nationality-
- iv) Place of birth-

Occupation-

- i) In the beginning
- ii) Later

Award received-

- i) National award and year
- ii) International award and year

Scrap book

- Draw or paste the picture of -
Mother Teresa, Mahatma Gandhi, Maharani Laxmi bai, Bhagat singh,
Subhash Chandra bose, Chandrashekhar Prasad, Lal Bahadur Shastri



Lesson - 15

The Glorious White Washer

Q1. Match the opposite words.

Like	careless
Happiness	neglect
Remember	sorrow
Notice	forget
Careful	dislike

Q2. Make new words

Faith	<div style="border: 1px solid black; border-radius: 10px; padding: 5px; display: inline-block;">ful</div>				
peace		_____			
truth		_____			
care		_____			
beauti		_____			

good	<div style="border: 1px solid black; border-radius: 10px; padding: 5px; display: inline-block;">ness</div>				
glad		_____			
happy		_____			
kind		_____			
polite		_____			

rich	<div style="border: 1px solid black; border-radius: 10px; padding: 5px; display: inline-block;">ing</div>				
fight		_____			
quarrel		_____			
heat		_____			
trade		_____			

Q3. Answer the following questions.

- i) What was the name of the town?
- ii) What was the work allotted to Tom?
- iii) Where was Jim going?
- iv) Who filled the air?

- v) Who were Tom's friend?
- vi) What attracted Jim?

Q4. Fill in the blanks

Brush, Saturday, Tom, Attention, lack

- i) It was _____ morning
- ii) White washed dipped his _____
- iii) Tom paid no _____
- iv) There was no _____ of material.
- v) _____ was flying in the street with his pail.

Q5. Add suffix and make new words

- I) Lock ii) Happy iii) Able
- iv) Less v) Till

Q6. Tick ✓ the correct and X the wrong one.

- i) Tom wanted to white wash the wall.
- ii) Ben had a sore toe.
- iii) Jim ate the apple.
- iv) Billy Fisher had a kite.
- v) Tom wanted to play with his friends.
- vi) Tom had the treasure of twelve marbles.

Q7. Write the meanings in Hindi

Allow, skinpping, white wash, employee, glorious, swing, idle, string, vegetation, plank, yard, sign, sore, dilapidated, harp, company, sold, doorknob, peel

Q8. Complete the puzzle with the help of following clues

- i) Young one of frog (7 letters)
- ii) You can see through it (5 letters)
- iii) A musical instrument (4 letters)
- iv) It was a dead (3 letters)
- v) Not the oranges, but the (4 letters)
- vi) Window (5 letters)
- vii) It was a tin (7 letters)
- viii) Some dogs have it (6 letters)
- ix) He got twelve of it (7 letters)

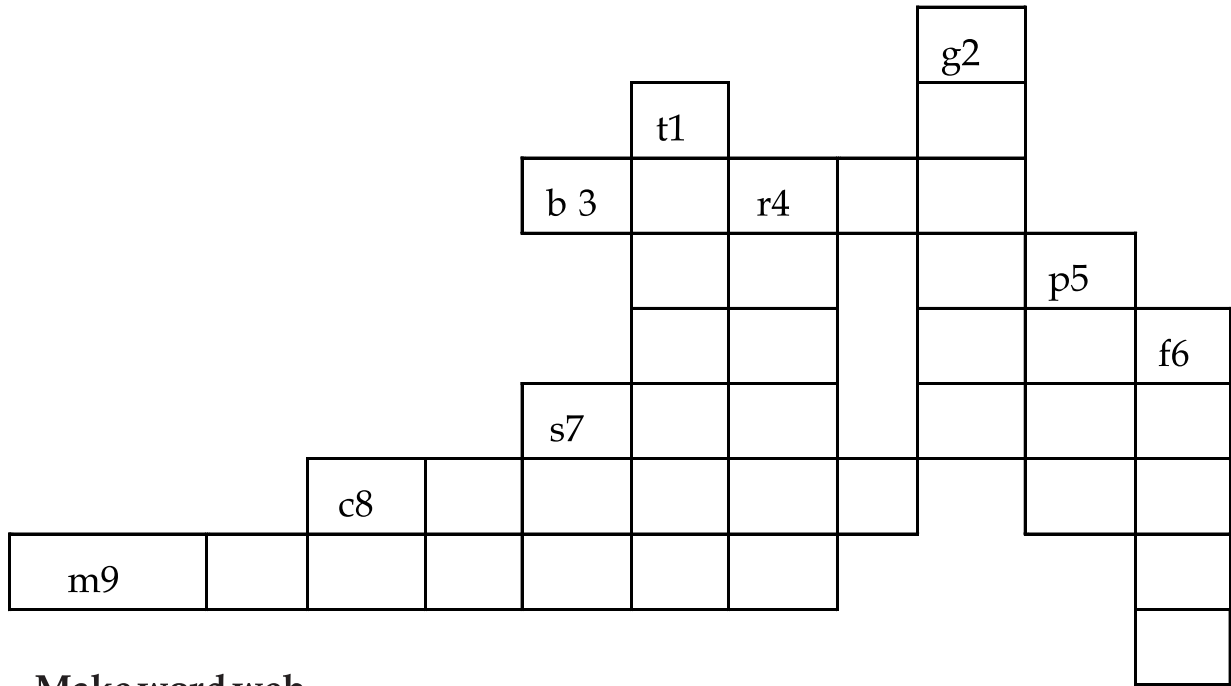

Q9. Make word web

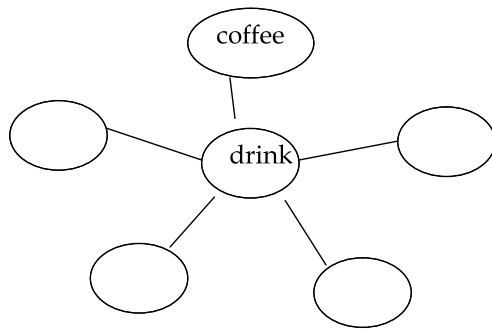

Q10. Rearrange the given letters

- | | | |
|--------------|------------|------------|
| I) Adtsaury | ii) Leldif | iii) Erfhs |
| iv) Soslbmso | v) Smemur | vi) Lberam |

Q11. Make rhyming words

- | | |
|----------------|---------------|
| i) Ring | _____ / _____ |
| ii) Vegetation | _____ / _____ |
| iii) Picnic | _____ / _____ |
| iv) Flying | _____ / _____ |

Assignment-

- Make a list of activities that people generally do in their free time.
- Make a story and write it in your own words.

Scrap book

- Collect a picture of white washer, painting brush and stick here.



Lesson - 16

Half -Way Down

Q1. Write meanings in hindi

stairs, sit, always, sorts, funny, thought, instead, bottom, top, nursery

Q2. Answer the following questions.

- i) What does I refer to in the poem?
- ii) Where does the child sit?
- iii) Why does the child like to sit there?
- iv) What is special about the stair where the child sits?

Q3. Complete the missing letters?

- | | | | |
|----------|-------------|------------|--------|
| i) Q_ite | ii) Inst__d | iii) H__d | iv)R_n |
| v) St_p | vi) St__rs | vii) Oth_r | |

Q4. Arrange the letters to make words

- | | | |
|------------|------------|--------------|
| I) portusp | ii) ptos | iii) innndgi |
| iv) airupr | v) yrusern | vi) otghtsu |
| vii) tiras | | |

Q5. Make rhyming words

Down, stair, head

Q6. Match the opposite words

- | | |
|--------|-----------|
| Top | unlike |
| Half | start |
| Always | full |
| Stop | bottom |
| Like | sometimes |

Q7. Make new words using given words

- | | |
|------------|-----------|
| Step _____ | Top _____ |
| lock _____ | nur _____ |
| u _____ | pur _____ |

Q8. Fill in the blanks

East, west, north, south

- i) Sun rises in the _____
- ii) Kanyakumari is situated in _____ direction.

- iii) Jammu and Kashmir is situated in _____ direction.
iv) Sun set in the _____

Q9. Write true or false.

- i) Stairs are useful for gardening.
ii) Children are playing with stairs.
iii) Leg help us to go upward.
iv) In nursery there are many types of plants.
v) Head is round in shape.

Q10. Complete sentences using 'has' and 'have'

- i) I _____ many pens.
ii) She _____ a beautiful box.
iii) Ramu _____ a black cat.
iv) We _____ colourful pens.
v) They _____ many balls.

Q11. Add 's' and make new words

Pot____, __top, Letter____, __even, __ort____,
__o, __tair, In__tead, Thought____,
Always____, Nur__ery, __pecial

Q12. Add 'less' and make new words

- i) Help + _____ = _____ ii) manner + _____ = _____
iii) use + _____ = _____ iv) hope + _____ = _____
v) meaning + _____ = _____

Assignment-

- Write the details about four direction.
- Write ten lines about temple, police station, and school.

Portfolio-

- Draw a picture of national flag and colour it.
- Draw a picture of post box.
- Draw a picture of temple.

Scrap book

- Collect some pictures of temple, post office, stairs, school, bus stand, hospital, police station, railway station and paste it.



Lesson - 17

Making Best out of Waste, Her forte

Q1. Match the following columns

- | | |
|-----------------|---------------------------------------|
| i) Masterpieces | centre of public attention |
| ii) Acclaimed | the best work of its type |
| iii) Exponent | appreciate |
| iv) Limelight | well known |
| v) Commend | a person who sets examples for other. |

Q2 Match the words with their Hindi meaning

- | | |
|----------------|--------------|
| i) Forte | अद्वितीय |
| ii) Exhibition | विशेष कौशल |
| iii) Unique | प्रदर्शनी |
| iv) Subtly | नया और जवान |
| v) Budding | चतुराईपूर्वक |

Q3. Fill in the blanks choosing appropriate words given below

flowers, nine, panthi, rama, artists, forty-four

R.K.Agrawal inaugurated the exhibition. It contained the work of three _____ namely Rukmani Chaturvedi, Kusum Lata Vaidya and _____ Dutt Joshi. In, all there was _____ paintings of these only _____ belonged to Ms. Joshi. Rukhmani chaturvedi used things like leaves, _____ etc. to make her collages. Internationally acclaimed _____ exponent Devdas Banjare was present at the inaugural function.

Q4. Write whether the statements are true/false in the bracket

- Rukmani used waste material for her artworks. (_____)
- General Manager V. k. Agrawal inaugurated the exhibition. (_____)
- Rukmani created impressive painting and collages. (_____)
- “Steel city” word is used for Raipur. (_____)
- Devdas Banjare was present at the inaugural function. (_____)

Q5. Make new words

Present	_____	Craft	_____
Commend	_____	End	_____

colour	_____	waste	_____
work	_____	leave	_____
part	_____	collage	_____
create	_____	serve	_____
organize	_____	use	_____
utilize	_____		

Q6. Choose the correct option from the bracket and complete the sentences.

- The Prime Minister ____ the seminar on energy conservation. (inaugurated / completed)
- Mother Teresa's name is an _____ for anyone who wants to do social services. (invitation / inspiration)
- The Expo was a opportunity for Ms. Rukmani. (unique / changing)
- Most of the people still use _____ as a fuel. (pencil / charcoal)
- The chief guest _____ the winners of different categories. (insulted / congratulated)

Q7. Give the following questions answer in one word.

- Which city was the Expo organized in?
- Who inaugurated the exhibition?
- How many participants were there to exhibit the things?
- When did the exhibition end?
- How many paintings did Ms. Rukanami exhibited?
- Who is the famous Panthi artist?
- To which city does Ms. Rama Dutt Joshi belong?
- Whose life is depicted in Ms. Joshi's paintings?
- Who used corn (maize) and banana - peels for her artworks?
- Which medium did Ms. Joshi use for her artworks?

Q8. Make a list of the things the participants exhibited.

Ms. Rukmani	Ms. Kusumlata	Ms. Rama Dutt

Q9. Make a list of the materials the artists used for their creation

Names	Material used

Q10. Use the appropriate form of verbs given in brackets in the sentences given below.

- i) She ____ art works made out of waste. (present / presented)
- ii) The chief minister _____ the fast food shop “star one” in Raipur recently. (inaugurate / inaugurated)
- iii) God ____ the world. (create / created)
- iv) Sania Mirza _____ the honour of entering in the Australian open. (achieved / achieve)
- v) The programme was _____ by the college. (organize / organized)
- vi) Paintings of local artists were _____ in the auditorium. (exhibit / exhibited)
- vii) President _____ the winners. (congratulated / congratulated)
- viii) The wind _____ the letter out of my hand. (blow / blowed)
- ix) He _____ his hand while playing cricket. (broke/ break)

Q11. Match the following sentences

	A	B
1	People bought her collages	milk is given by cow.
2	Bhilaian appreciated her art	her collages were bought by people
3	The management selected her for the state award	she was contacted for guidance by many people
4	Many people contacted her guidance	Her art was appreciated by Bhilaian
5	Cow gives milk	She was selected for the state award by the management

Q12. Complete the spelling of following words

- | | | | |
|-------------|----------------|---------------|--------------|
| Fo__t__ | W__s__e | __nique | Ex__ibit__n |
| I__aug__rat | Co__la__e | __mpr__ss__ve | S__bt__y |
| __rt | In__pir__tio__ | O__pi__t | Li__el__g__t |

Q13. Write the meaning of following words in Hindi.

masterpiece	acclaim	utilize	gamut
depict	inspiration	charcoal	forte
waste	congratulate	expo	exhibition
inaugurate	subtly	collage	

Q14. Answer the following questions

- i) "Her" word is used for whom in the lesson?
- ii) Where has this report been taken from?
- iii) Which city was the Expo organized in?
- iv) How many paintings were exhibited by Ms. Vidya?
- v) Who inaugurated the exhibition?
- vi) This exhibition was a great opportunity for whom?
- vii) Who is acclaimed Panthi exponent?

Q15. There are two stories mixed up. Arrange the paragraphs in order to find out the stories.

A mango tree said to a bush growing in its shade, "you are useless. No body wants you. I am used for roofs and houses every- where. Men can't do without me"

The Young deer was filled with fear and forgetting his resolves, look to his heels, along with his mother.

"here is a man coming to you with an axe, right now. Farewell"

A young deer said to his mother, "I am larger than a dog and swifter and I have horns to defend myself. When dogs appear I will run away with the others. I have decided not to run from dogs in future."

"You are so right", said the Bush. Just then they heard the bark of dogs.

Q16. Look at the picture given below and write related headlines under each picture given in the box.

- i) Cute cats at home.
- ii) How do ostriches fly?
- iii) Running with hero
- iv) Defeated by pride

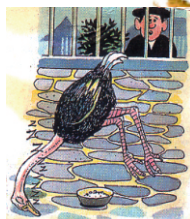

Assignment-

- Write the name of any five things, which are made of wastes.
- At the end of the following words add 'd' and make new words
change, hear, shade, congratulate, inaugurate
- At the end of the following words add 'ed' and make new words.
impress, express, acclaim, attempt, cover

Portfolio

- i) Make a collage of your own with beads / paper bits and leaves and show in the class.



Lesson - 18

Dear Dairy

Q1. Match the columns

- | | |
|------------------|----------------|
| i) Chitrakut | Bahleshwari Ma |
| ii) Kanger vally | Water fall |
| iii) Kutumsar | Danteshwari Ma |
| iv) Dantewara | National park |
| v) Dongargarh | caves |

Q2. Write true/false in the bracket.

- i) Blind fishes are found in the Shankar kund. (____)
- ii) Shankani and Dankani are the rivers. (____)
- iii) Waterfall is situated in Kutumsar . (____)
- iv) Bamleshwari temple has 1000 steps. (____)
- v) The name of the girl in the lesson is Rama. (____)

Q3. Choose the correct word from the bracket and fill in the blanks.

Danteshwari, waterfall, peacocks, Nani ma's, steps

- i) There are 1000 _____ in Bamleshwari temple.
- ii) _____ is situated in chitrakut.
- iii) Danteshwari is famous for _____ temple.
- iv) I saw _____ in kanger valley National park.
- v) We went to Durg to our _____ house.

Q4. Choose the correct word and complete the sentences.

church, temple, mosque, gurudwara, mathrua

- i) Place of worship for Hindu is _____
- ii) place of worship for Christians is _____
- iii) Muslims worship in _____
- iv) Sikhs worship in _____
- v) The birth place of lord Krishna is _____

Q5. Make new words

- | | |
|-------------|--------------|
| Bag _____ | Hour _____ |
| Place _____ | Pigeon _____ |
| Cave _____ | Pack _____ |

Sleep _____
 Cry _____
 Arrange _____
 Employ _____
 Enjoy _____
 House _____
 Meaning _____

Sing _____
 Swing _____
 Pay _____
 Develop _____
 Cher _____
 Use _____
 Joy _____

Q6. Make a word list related to given word

i) Journey ii) Traditional

Q7. Complete the table

S.no	Where	How	What
1	Jagdalpur	Train	Chitrakut waterfall
2			
3			
4			
5			
6			

Q8. Complete the puzzle with the help of clues. One is done for you.

Clues-

9
 1 G A R D E N
 8
 2
 11
 3
 4
 12
 5
 6
 7
 10

- i) Brindavan (6 letters)
- ii) Place of worship for Christians (6 letters)
- iii) Chitrakut (9 letters)
- iv) Kanger valley National (4 letters)
- v) Muslims worship here (4 letters)
- vi) Kumtuar (4 letters)
- vii) Red (4 letters)
- viii) Baila dilla (4 letters)
- ix) Sikhs worship here (9 letters)
- x) English term for 'ghati' (6 letters)
- xi) Hindu worship here (6 letters)
- xii) Large area of water surrounded by land starting with L (4 letters)

Q9. Give answer of following questions in one word

- i) Who is Asha's brother?
- ii) Where is Munni Mousie's house?
- iii) On which date they started their journey for Jagdalpur?
- iv) Where is Nani ma lives?
- v) How many steps are there in Bamleshwari?
- vi) When they realied waterfall?
- vii) Where is Kutumsar caves situated?
- viii) Who made 'Aloo paratha'?
- ix) Who is Munni Mousie's son?
- x) Where is blind fishes found?

Q10. Rearrange these events according to lesson.

- i) We started for Kanger vally on 30th June 04.
- ii) We reached at Dongargarh on 4th July 04.
- iii) We visited the Chitrakut waterfall on 29th June 04.
- iv) We went to Dantewads on 1st July 04.
- v) We started for Jagdalpur on 27th June 04.

Q11. Answer the following questions.

- i) Give the names of children mentioned in the diary.
- ii) Which place do you think Babloo liked most?

- iii) What was there in the garden of Munni Mousie?
- iv) Why did Asha feel that her parents were partial?
- v) How many buildings are there in Danteshwari temple?
- vi) Write the name of birds and animals which they saw in Kanger Valley National Park?

Q12. Use the following words in your own sentences.

arrangements, frightened, drive, partial, surroundings

Assignment-

Imagine that you went on a tour with your family. Write a brief description of the first two days of your tour giving the following information.

- i) When and where did the tour start?
- ii) What places / sites did you visit?
- iii) When and where did you eat?
- iv) Did you see any cultural programme?
- v) What things did you buy?

Scrap book-

- Paste some pictures of tourist places.



Lesson - 19

From Tomorrow on

Q1 Match the following

Glad	daily
Bitter	next day
Sad	happy
Tomorrow	fact or event that is difficult to accept
Everyday	unhappy

Q2. Here are some words given in the box. Make sentences using these words.

happy, angry, sad, frightened, surprised

Q3. Fill in the blanks with the given in the bracket.

- i) I feel _____ (sad / happy) when I've done something well.
- ii) People hurting each other makes me feel _____ (happy / sad)
- iii) My friend is _____ (afraid / dare) of big dogs.
- iv) I get _____ (confused / defused) when asked to sing a song on the stage.

Q4. Complete the poem with the words given in the bracket.

not, today, from, bitter, sad

From tomorrow on I shall be _____, _____ tomorrow on.

Not today, _____ I shall be glad, and every day, no matter how it may be
_____ I shall say: from tomorrow on I shall be _____ today.

Q5. Answer the following questions

- i) When will the child become sad?
- ii) What does she want to be today?
- iii) "from tomorrow on I shall be sad" - what does the child mean when she says so?
- iv) Who is 'Anne Frank'?
- v) Write the name of the poem?

Q6. Find the odd one and circle it-

- i) Sad, glad, bad, pen
- ii) Tomorrow, cow, borrow, sorrow
- iii) Bitter, fitter, glitter, light
- iv) Key, bay, may, say
- v) Shall, ball, fall, cell





Q7. Write the missing letters

- i) Tomo ___ow ii) ___oday
 iii) Ever__day iv) ___hall v) M__tter

Q8. Write Rhyming words of the following.

- i) Glad _____, _____ ii) Say _____, _____
 iii) Be _____, _____ iv) Dear _____, _____
 v) Bat _____, _____

Q9. Match the following

		angry
		crying
		shocked
		happy
		sad

Q10. Made new words

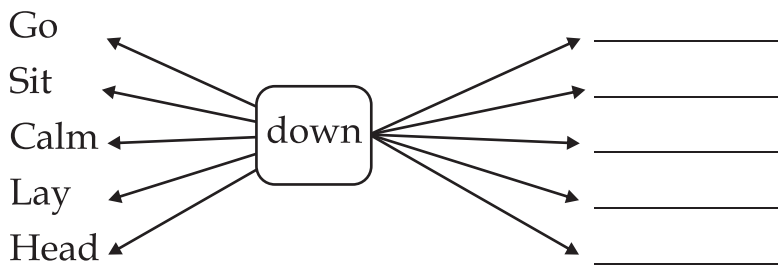
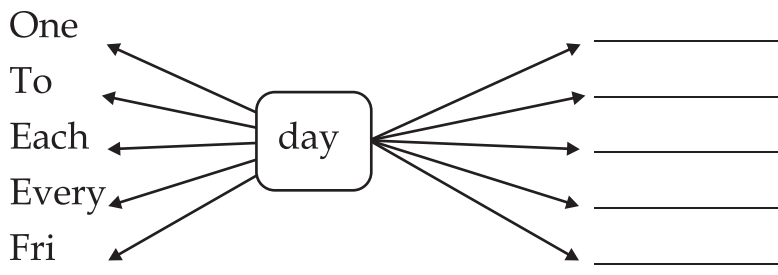

Assignment-

- Write the poem- 'from tomorrow on'



Lesson - 20

Unfriendly Nature

Q1. Match the columns

- | | |
|---------------------|-----------------------------------|
| i) Natural disaster | lesser rainfall |
| ii) Earthquake | heavy rainfall |
| iii) Flood | sudden changes in the environment |
| iv) Drought | violent shocks, release of energy |

Q2. Choose the correct option and put a tick mark ✓ on it.

- i) Natural disaster is-
- (a) Earth quake (b) Train accident
- ii) Earth quake is measured by
- (a) Thermometer (b) seismograph
- iii) "soil erosion" is the result of
- (a) Flood (b) Drought
- iv) "Lack of drinking water" is the result of
- (a) Drought (b) Earthquake
- v) Villages of Bikaner praying for-
- (a) Rain (b) Bus

Q3. Write true/false in the bracket

The earth quake in Gujarat in 2001 killed 13000 people.

We should run out of homes as soon as we feel tremors.

We should bend down under cots and desks during floods.

- i) 70000 people became homeless in Assam due to earth quake. (____)
- ii) Eating food that has got wet in flood water is harmful. (____)
- iii) The local radio warns us about earthquake and floods. (____)
- iv) People in Bikaner always enjoy rains. (____)
- v) The villagers become poor and unemployed due to drought. (____)
- vi) The earth quake is a natural disaster. (____)
- vii) A flood occurs due to lesser rain fall. (____)

Q4. In which conditions we do the following things. Choose the correct answer given in bracket.

- Bend down under a desk or cot, stay there still the shocks stop. (drought /

earthquake)

- Keep medicines, strong ropes, radio , torch and batteries. (earth quack / flood)
- Collect and store rain water. (drought / flood)
- Stop driving during tremors. (flood / drought)
- Grow plant and care for them. (flood / drought)

Q5. Complete the sentences with the help of following words.

Earth quake, flood, drought

- Don't use the lift in big buildings during the _____
- Drink boiled water during the _____
- Don't misuse or waste water during the _____
- Don't travel just after an _____
- Don't eat food that has got wet during the _____

Q6. Write the missing letters and complete the spelling

Tre_o_ t_em_le fo_de_
 c_ll_de sei_mogr_ph _rop
 _ood s_ock _ou_ht _ide

Q7. Write the meanings of following words in Hindi

Earthquake, flood, drought, natural disaster, fodder
 Rainfall, soil erosion, scarcity crop, restore

Q8. Answer the following questions

- What is an earth quake?
- What is a natural disaster?
- What happens when the water flows or rises above the river/ sea?
- What happened when large plates of land collide with each other and released energy?
- Which instrument is used for measuring earthquake?
- What we can do during an earthquake?

Q9. Complete the word web about an earth quake

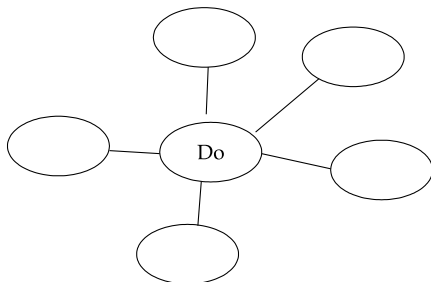

Q10. Complete the word web about the flood.

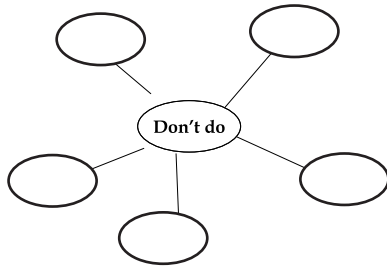

Q11. Tick ✓ the word that is not related to those written in capitals. Take the help of your dictionary

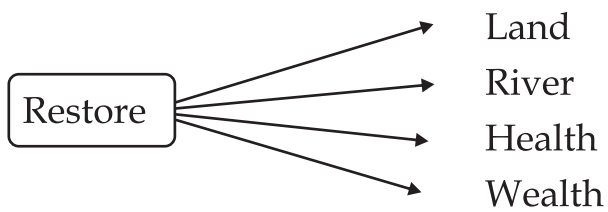
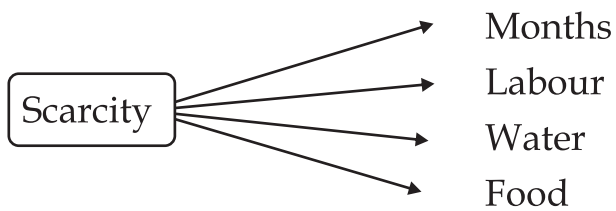
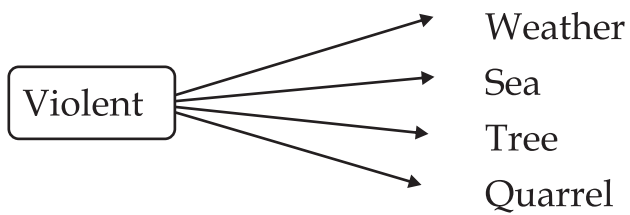
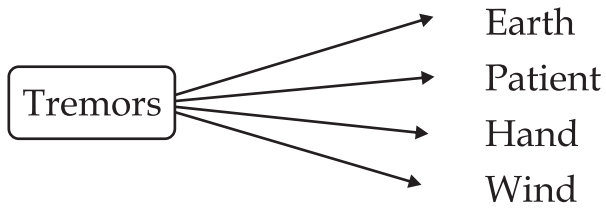

Q12. Match the following sentences with correct suggestion.**Assignment-**

1. How did flood affect the following?
 - (a) People and cattle
 - (b) Trees
 - (c) Houses
2. How did earth quake affect the following?
 - (a) People
 - (b) Building
3. How did drought affect the following?
 - a. Corps
 - b. Cattle

Portfolio-

- Write slogans on “Disaster awareness” on sheets to display in your class.

Sentences	Suggestion
I worked hard today. I feel tired now	You must go to your home
My mother will get angry. I am getting late	You must take some medicine
I have a headache. I can't work now	You must take rest now
My hand writing is very poor. I feel it	You must join music class
She wants to be a singer in future. She doesn't sing very well now	You must obey your elder
She is a very naughty girl . She doesn't obey elders	You must do some practice for it



Lesson - 21

The Great Sculler

Q1. Write true/false in the bracket

- i) Bobby Pearce's father was a sculler. (____)
- ii) Bobby started sculling at a young age. (____)
- iii) Bobby's father asked him to take part in the contest for fourteen year olds. (____)
- iv) When he was a 5 year old boy, Bobby competed with fourteen year olds. (____)
- v) Bobby Pearce won only one Olympic medal. (____)
- vi) Bobby's father was a good sculler. (____)

Q2. From the puzzle given below find words which mean-

- i) Continue, do not stop
- ii) Make the speed less
- iii) Wake from sleep
- iv) Making the speed better
- v) Any other meaningful word you can find.

R	V	N	S	P	T	S
B	U	C	K	U	P	L
E	Z	D	R	A	A	O
P	I	C	K	U	P	W
L	Q	B	R	N	O	D
G	E	T	U	P	L	O
S	T	G	J	H	F	W
C	A	R	R	Y	O	N

Q3. Choose the correct answer and put a tick ✓ mark on it.

- i) What would you say when you lost your mobile
(a) Oh no! (b) Well done!
- ii) What would you say when someone did well
(a) Well done (b) Hurrah!
- iii) What would you say when your friend leading a race
(a) Buck up! (b) He has done it!
- iv) What would you say when your friend finally win a race
(a) Oh no! (b) He has done it!
- v) What would you say when you passed your exam.
(a) Hurrah! (b) He has done it!

Q4. Rewrite these sentences in proper sequence

- i) Bobby waits for the ducks to cross.
- ii) Bobby hears a sound : quack-quack
- iii) Now again he picks up speed.
- iv) The crowd is mad.
- v) Finally bobby Pearce win the race.

Q5. Write the missing letter and complete the spelling

Pr_pa_e A_mir_ _rriv_
 Mil_io_ Cham_ionsh_p C_nte_t
 _inal Po_si_le Twe_ty Sc_l_er

Q6. Write the meaning of the following words in Hindi

Sculler Admire Prepare Arrive Million
 Contest Final Suddenly Duckling

Q7. Give the answer of following questions in one word.

- i) What is the full name of Bobby?
- ii) Which medal Bobby won in sculling contest?
- iii) In which age Bobby take part in the Olympics at Amsterdam?
- iv) Who came in the course of Bobby between the race?
- v) Who run the race finally?

Q8. Make new words

Scull	_____	Admire	_____
Lead	_____	Old	_____
Slow	_____	Arrive	_____
Go	_____	Race	_____
Pass	_____	olympic	_____

Q9. With the help of following words make five questions. One is done for you.

Have you ever	midden	a buffalo	?
	gone	to school	
	climbed	a coconut tree	
	flown	an aeroplane	
	played	in the rain	
	made	jalebis	

Example- Have you ever ridden a buffalo?

Q10. Answer the following questions

- i) At the sculling club Bobby made a promise. Did he keep it?
- ii) Do you find anything uncommon in Bobby and many successful player. What is it?
- iii) Who was sculling just behind Bobby Pearce?
- iv) "Bobby Pearce won the race and also the hearts of millions of people." Does everyone who wins a race not winning the hearts of people? Give your opinion.
- v) Pick up words from the text that people said when Bobby was slowing down.

Q11. Write the incident of Bobby Pearce and the duck in your own words.

(Hint: Bobby takes part, leads, slows down, picks up speed, saves the ducks)

Q12 Complete the word web with the name of games

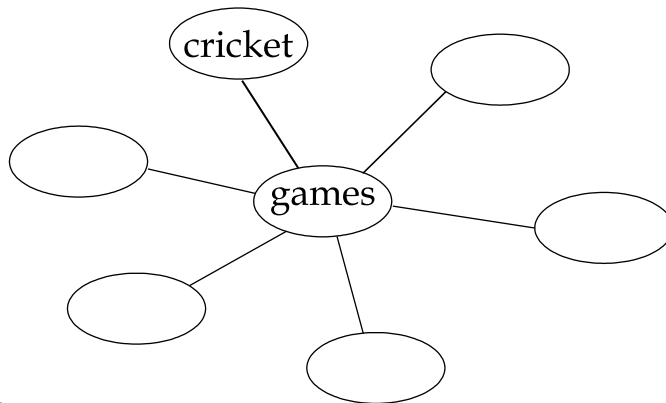

Assignment-

- Write two water's game.
- Write the name of five outdoor games
- Write the name of five indoor games.
- Make a list of well known players of your school and state.
- Write the number of players in these games-

Cricket, Hockey, Football, Kabbadi, Tennis

Portfolio-

- Draw or paste the picture of following
A bat, a foot ball

Scrap book

- Paste the picture of different games.



प्रश्न बैंक
अंग्रेजी

कक्षा - 8

Lesson - 1

Water's for

Q1. Match the column

- | | |
|--------------|----------|
| i) Cleaning | the dirt |
| ii) Shining | tomatoes |
| iii) Rinsing | a car |
| iv) Watering | the bath |
| v) Shifting | a shirt |

Q2. Match the rhyming words

- | | |
|-----------|-------|
| i) Shirt | pea |
| ii) Mad | sleet |
| iii) Feet | dirty |
| iv) Tea | day |
| v) Say | dad |

Q3. Fill up the blank with the given words

Shining, watering, cooking, drinking, washing

- Riya is _____ tea.
- I'm _____ food.
- Mummy is _____ my clothes.
- Ramu is _____ the tomatoes.
- Deepak is _____ his car.

Q4. Complete the poem with the given words

Drinking, rising, shining, cleaning, sifting

- Water is _____
- Washing, _____
- Making tea
- _____ the bath
- _____ a car
- _____ a shirt
- Watering tomatoes,
- _____ the dirt

Q5 Match the following



Drinking water



Shining a car



Watering the plant



Scrubbing



shifting the water

Q6. Choose the correct word from the bracket for underlined words.

- i) Washing tea (making / cleaning)
- ii) Scrubbing a car (shining / rinsing)
- iii) Watering me (drinking / scrubbing)
- iv) Shifting the bath (washing / cleaning)
- v) Drinking tomatoes (watering / rinsing)

Q7. Say true/false according to the poem.

- i) I'm cleaning the dirt. (_____)
- ii) I'm making tea. (_____)
- iii) I'm rinsing a car. (_____)
- iv) I'm watering tomatoes. (_____)
- v) I'm scrubbing a shirt. (_____)

Q8. Look at the picture and write what he/she is doing.



.....



.....



.....



.....



.....

Q9. Write the names of five water sources.

Q10. Write one rhyming word for each

i) Make _____

ii) Fly _____

iii) Rain _____

iv) Shirt _____

v) Game _____

Q11. Write five words which ends with "ing".

Q12. Complete the word web.

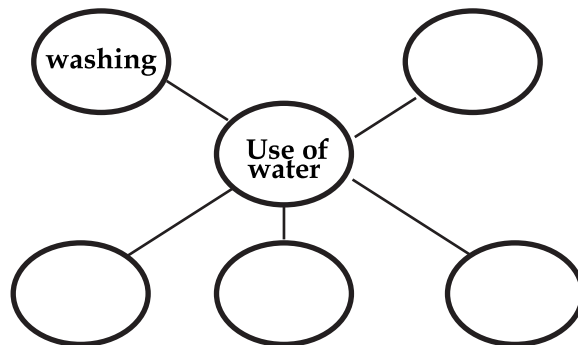

Q13. Write the meaning of the following words in Hindi.

Scrub, rinse, dirt, puddle, spray, sleet, squirting, soak, pie, mud

Q14. Write five uses of water.

Q15. Find out the naming words from the given poem.

Example- Water's for watering plants

Washing drinking

Making tea

Cleaning the bath

Or scrubbing me;

Shining a car

Or rinsing a shirt

Watering tomatoes,

Shifting the dirt

My mum says.

Q15. Make new words by adding "ing"

i) Water	_____
ii) Clean	_____
iii) Drink	_____
iv) Soak	_____
v) Mix	_____
vi) Splash	_____

Q16. Complete the word map. What is water used for?

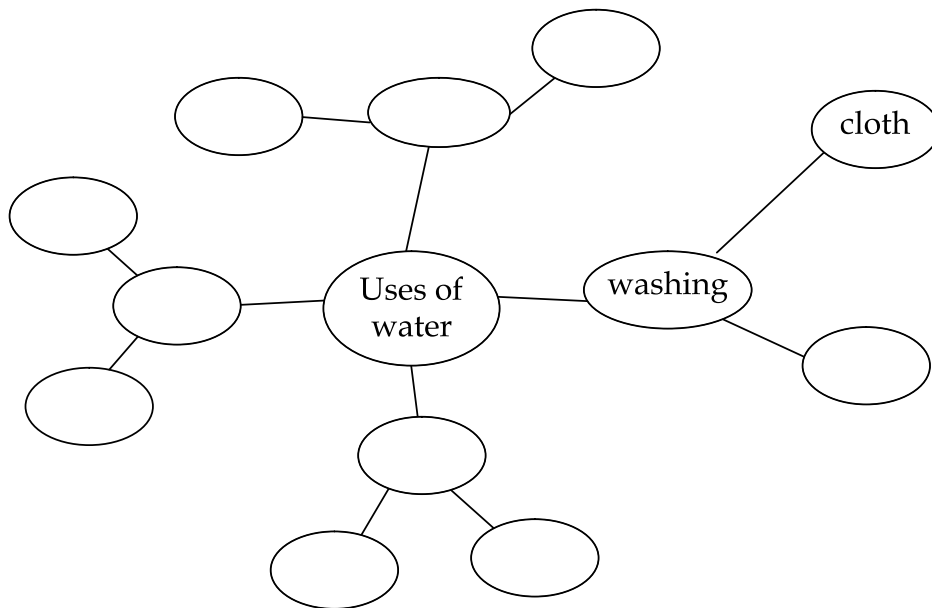

Q17. Draw the picture of two uses of water.

Q18. Find out the five uses of water from the puzzle and write.

Q	C	L	E	A	N	I	N	G
R	G	H	B	D	E	C	O	M
L	P	C	O	O	K	I	N	G
T	D	R	I	N	K	I	N	G
W	A	S	H	I	N	G	U	S
O	X	R	I	N	S	I	N	G
B	W	A	T	E	R	I	N	G
Z	V	T	L	M	N	Q	R	P
X	M	O	P	Q	S	T	U	Y

Q19. Make sentences by using these words

Drinking, washing, making, playing, cleaning



Lesson - 2

The Shoemaker and the Elves

Q1 Match the column

The shoemaker wanted to sew shoes	One hundred
When the shoemaker saw a better pair of shoes, he was	Rags
The elves wore	Elves
The beautiful shoes were made by	Next day
How many gold pieces were given to the shoemaker	surprised

Q2. Fill up the blanks with the given words in the bracket.

Stitches, rags ,excellent, curtains, elf

- i) A fairy like creature with painted ears is called _____ -
- ii) We use _____ to clean the floor.
- iii) _____ are hung at doors and windows.
- iv) He is an _____ cricket player
- v) The _____ on these trousers are very fine.

Q3. Tick the correct answer.

- i) The shoe maker lived in a _____
(a) Little house (b) big house (c) hut (d) building
- ii) The shoemaker was a _____
(a) Rich man (b) poor man (c) wise man (d) good man
- iii) Who gave the gold pieces to shoemaker?
(a) Queen (b) king (c) elves (d) fairies
- iv) The shoemaker wanted to sew new shoes.
(a) the next day (b) at mid night (c) early in the morning (d) the previous day
- v) The beautiful shoes were made by
(a) Joker (b) elves (c) magician (d) fairies
- vi) When the shoemaker saw a better pair of shoes he was
(a) Annoyed (b) surprised (c) very sad (d) happy
- vii) The elves wore
(a) Over coat (b) rain coat (c) suit (d) torn cloths

Q4. Say whether the following statements are true/false.

- (a) The shoemaker was very poor. (_____)
- (b) The shoemaker was surprised when we saw a better pair of shoes. (_____)
- (c) The shoes were made by the elves at night. (_____)
- (d) The elves wore beautiful clothes. (_____)
- (e) The shoemaker and his wife made little coats and trousers for the elves. (_____)

Q5. Answer the following questions.

- (a) Where did the shoemaker live?
- (b) What did the shoemaker do when he saw a better pair of shoes?
- (c) What did the shoemaker and his wife give the little elves?

Q6. Make some new words by adding 'ian'

Music _____
 Electric _____

Cricket _____
 Play _____
 Read _____
 Own _____
 Report _____
 Sing _____

Art _____
 Guitar _____
 Tour _____

Q7. Rearrange the letter and write the correct spelling.

- i) Sheo _____
- ii) Wodo _____
- iii) Swe _____
- iv) Spho _____
- v) Evles _____

Q8. Make some new words using "ful" and "ed"

Example- beauty + ful = beautiful

Play + ed = played

Q9. Write one rhyming words for each

- i) Fine _____
- ii) Wood _____
- iii) Object _____
- iv) Match _____
- v) Shoe _____

Q10. Answer the following questions

- i) Why was the shoemaker poor?
- ii) How did the shoemaker become rich?
- iii) Why did the little elves never come back?

Q11. Complete the word web by the word related with shoes.

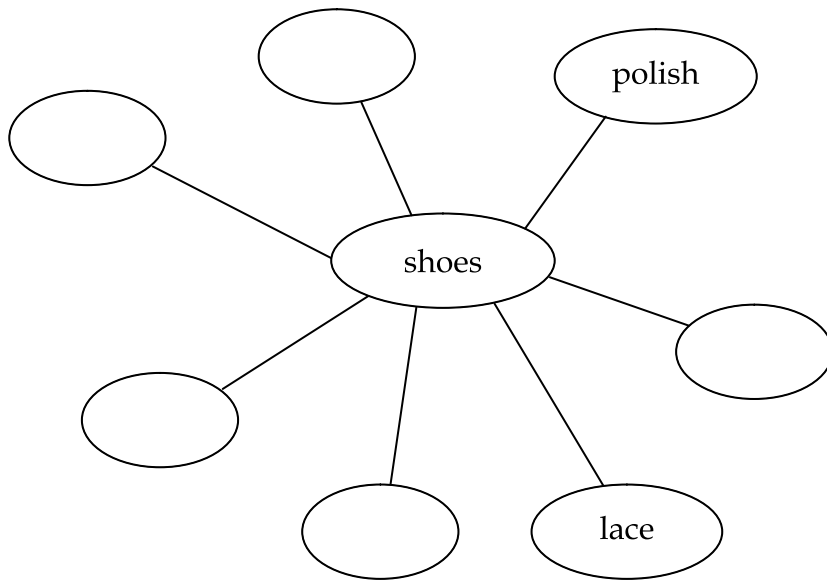

Lesson - 3

Measure for Measure

Q1. Write the meaning in Hindi

Poets, patronage, fine arts, brilliant, portrait, , error, characters, morsel, carpenter, chief minister

Q2. Tick the correct answer

- i) Who was invited to draw the king's portrait?

(a) Tenali Raman	(c) Raja Varma
(b) Carpenter	(d) elders of the town
- ii) What did the artist get as a reward?

(a) Money	(c) praise
(b) Chief ministership	(d) kingdom
- iii) The artist's administration made the people of the kingdom?

(a) Happy	(c) unhappy
(b) Satisfied	(d) pleased
- iv) He king realized that the food was-

(a) Badly cooked	(c) well cooked
(b) Not cooked	(d) half cooked
- v) Krishna Devaraya was found of-

(a) Dancing	(c) singing
(b) Fine arts	(d) fishing

Q3. Choose the most suitable phrase that will help to complete the sentence

all senses, come across, close and near, suffer and die, unbearably hot

- i) Raja Verma became _____ to the king.
- ii) The food was _____
- iii) Do you want us to _____
- iv) I have never _____ such a excellent carpenter.
- v) The king asked Raman whether he had lost _____

Q4. Match the column with the photographs and mention what these people are famous for



His birthday is celebrated as children's day



Father of the Nation



Freedom Fighter

Q5. Match the following

- | | |
|---|--|
| i) A king support to someone | incompetent |
| ii) Things are in a mess | a morsel of food |
| iii) When a person is not doing his job well | chief minister |
| iv) A person who looks after | disorder the administration of a state |
| v) Some thing that you would want when you are hungry | patronage |

Q6. Answer the following questions

- Why were the people unhappy with Raja Verma's administration?
- What was Tenali Raman's plan to remove the artist from his new job?
- What does the title 'Measure for Measure' mean?

Q7. Find the sward part of the given words.

- Example- brill__iant = brilliant
- Prom__rait = _____
 - Horr__ward = _____
 - Port__ible = _____
 - Re____nd = _____
 - Gra____inent = _____

Q8. Frame your own sentences using these words.

King, carpenter, chief minister, unhappy

Q9. Draw the portrait of your best friend and write his/her name?**Q10. Draw two characters from Puranas / Mahabharat / Ramayan and name them.****Q11. Match the sentences from column A to column B**

- | A | B |
|------------------------------|--------------------------------|
| i) The king was very pleased | that the food was badly cooked |
| ii) He became close | called to cook food |
| iii) The king realized | resigned from his post |
| iv) A carpenter | and dear to the king |
| v) Raja Verma | with the artist |

Q12. Match the following with their meaning

- | | |
|-----------|------------------------------|
| Brilliant | a prize in return of service |
| Portrait | royal, very good |
| Majestic | easily seen |
| Prominent | picture or sketch |
| Reward | extremely good |

Q13. Separate the root word from the following-

Example :- serving - serve

- i) Removing - _____
- ii) Preparing - _____
- iii) Harmless - _____
- iv) Eating - _____
- v) Laughing - _____

Q14. Supply the appropriate words given and complete the paragraph

Frame, majestic, alive, king, pleased, portrait, handsome

The _____ was very _____ with the artist when his _____ was ready. In the portrait, the _____ and king seemed to have come _____ within the _____

Q15. Read the passage and do the exercise-

Shaikh Mohammad Hanif, a peon at Mumbai Churchgate Railway Station. Saw a bag laying at a gate outside his work place. For then minutes, Hanif waited to see if anyone could claim for it. He then took the bag to his office and opened it. Inside was a veritable treasure a cell phone, a camcorder, three watches, traveler's cheques worth \$25000 and \$40000 in cash. There was also the Saudi passport of a man called Ashraf.

Put the tick \checkmark and X in the boxes

- i) Sheikh Mohammad was a clerk.
- ii) Hanif saw a purse lying at the gate.
- iii) He opened the bag in his house.
- iv) The bag contained the following things
 - (a) A cheque worth & 25000
 - (b) Cash of & 50000.
 - (c) Dubai passport
 - (d) Camcorder
 - (e) Cell phone
 - (f) Two watches
 - (g) Passport Ashraf's



Lesson - 4

The Tree That Never Stopped Giving

Q1. Fill up the blanks with the words given

tired, forest, stripped, boy, naughty

- i) there lived a _____ boy in a village.
- ii) I am the king of the _____
- iii) The _____ said he needed money.
- iv) The boy _____ the tree of every single mango.
- v) Finally the boy became a _____ odd man.

Q2. Arrange these words in alphabetic order.

grow, great, generous, gradually, crown, complain, courage, declare, delight, approach, aged, stump, enough, sullen, trunk

Q3. List out the fruits from the group of words

potato, mango, banana, onion, carrot, orange, grapes, brinjal, papaya, pumpkin, guava, lady's finger

Q4. Give one word related to following family of words.

- i) leaves, fruit, branches, trunk = _____
- ii) crown, rule, kingdom, palace = _____
- iii) tears, worry, cry, sorrow = _____
- iv) sailor, across, river, travel = _____
- v) hour, day, week, month = _____

Q5. Arrange the letters and make meaningful words. (clues are provided)

- i) Nwroc _____ (the king wears it)
- ii) tsofer _____ (where wild animals live)
- iii) lgitedh _____ (very happy)
- iv) nsilge _____ (one, only)
- v) mupts _____ (what remains after the trunk is cut of a tree)

Q6. Fill in the blanks with the correct words from the bracket.

- i) The tree aged _____ (slowly / humbly)
- ii) The tree declred _____ (stupidly / proudly)
- iii) The tree _____ (lonely / happily)
- iv) The boy became a tired old man _____ (slowly / finally)
- v) The boy got _____ (married / worried)

Q7. Tick ✓ the correct answer

- i) The boy made a crown

- (a) Of the tree (c) of the tree's leaves
 (b) Of the tree's flowers (d) of the tree's stump
- ii) Every day the boy spent hours
 (a) Near the big and tall mango tree.
 (b) Near the large and huge mango tree.
 (c) Near the large and old mango tree.
 (d) Near the long and huge mango tree.
- iii) The boy came back
 (a) Playing and singing
 (b) Happy and satisfied
 (c) Sullen and complaining
 (d) Running and dancing
- iv) The boy sat down in the warm sunshine on
 (a) Grassy ground (b) The tree stump
 (c) A bench (d) The branch of the tree
- v) Finally, the boy became
 (a) Young and handsome man (b) A thoughtful person
 (c) A bench (d) The branch of the tree

Q8. Find the correct word with the help of clue given below. One is done for you.

People and animal rest under trees.

It is cool during day time. Shade

i) It is used in our daily life.

We get wood for furniture from it. T_____

ii) It is a stage after flowering .

People eat it _____ I ____

iii) The part of the tree that helps it to stand firmly. _____ t

iv) We can't live without it . It helps plants grow. _____ e ____

v) The part of the tree that remains after cutting it down. _____ u _____

Q9. Write the part tens for these verbs :

- | | | | |
|------------|---------|-------------|---------|
| i) Live | = _____ | ii) Spend | = _____ |
| iii) Love | = _____ | iv) Pass | = _____ |
| v) Stop | = _____ | vi) Grow | = _____ |
| vii) Hack | = _____ | viii) Feel | = _____ |
| ix) Miss | = _____ | x) Need | = _____ |
| xi) Offer | = _____ | xii) Strip | = _____ |
| xiii) Sell | = _____ | xiv) Get | = _____ |
| xv) Marry | = _____ | xvi) Become | = _____ |
| xvii) Can | = _____ | xviii) Call | = _____ |

Q10. Read the paragraph carefully and pick out the describing words (adjective)

There lived a naughty boy in a village. He was a tall boy. He played with a happy girl who was always busy on a small computer. She made beautiful picture with a long pencil.

Q11. Read the lesson again and make a list of the problems of the boy and solutions provided by the tree. An example is done for you.

S. No.	Problem	Solutions
1	The boy needed money	The tree gave the boy fruit to sell
2	The boy needed a home	
3	The boy needed a boat	
4	The boy became tired	

Q12. Make new word with 'ing'

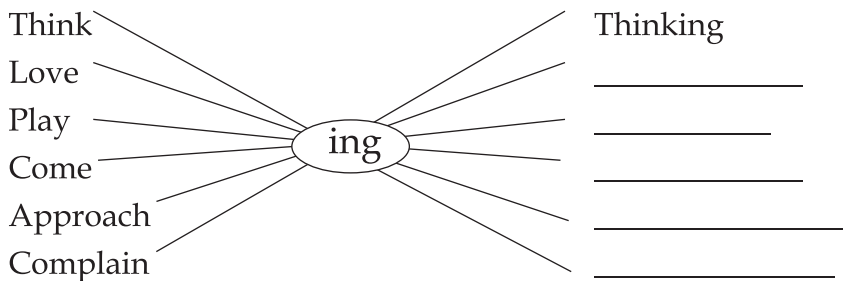

Q13. Use the situation given in the box to frame sentences add a noun or pronoun

Example- He doesn't know how to play cricket

Has not brought his water bottle is not able to open the door does not know what time the bus leaves has fallen down and hurt himself has lost his way in the mela / fair

Q14. What do we plant when we plant a tree?

We plant _____ / _____ / _____
 _____ / _____ / _____

Q15. Write the names of five flowers.

Q16 Write the names of five furniture made of wood.

Q17. Make three rhyming words for each

- i) Tree = _____ / _____ / _____
 ii) Make = _____ / _____ / _____
 iii) Need = _____ / _____ / _____
 iv) Warm = _____ / _____ / _____
 v) Near = _____ / _____ / _____
 vi) Old = _____ / _____ / _____

Q18. Answer the following questions

- Make a list of the things that help a tree to live.
- The boy looked sullen and complaining why?

Q19. Write about trees in five sentence.

Q20. Draw the picture of a mango tree.

Lesson - 5

Alice in Wonderland

Q1. Categorize the words in the table given below.

Antakshari, cricket, chess, icecream, puri, basketball, volleyball, rasgulla, hockey, halwa, jalebi, tennis, noodle, nadipahad, potato, samosa, roti, caroms, gilli-danda, alupoha, kabaddi, paratha, badminton, cream roll

Games	Food

Q2. Match the verbs in column A to the second form of verbs in column B.

A	B
Make	Brough
Hear	Stood
Bring	Made
Stand	Heard
Decided	Did
Do	Blew
Blow	Picked
Jump	Decided
Pick	jumped

Q3. Fill in the blanks to read lessons.

The _____ tells you about it. The queen of _____. She made some _____. All on a _____.
The mnaic of hears he state and took them quite _____

Q4. Answer the following question ?

- i) How did the king look like?
- ii) Why did the king look angry?
- iii) What did the white rabbit do?
- iv) Who was called to the jury box.
- v) Who state the tacts.

Q5. Write down five words related to the king.

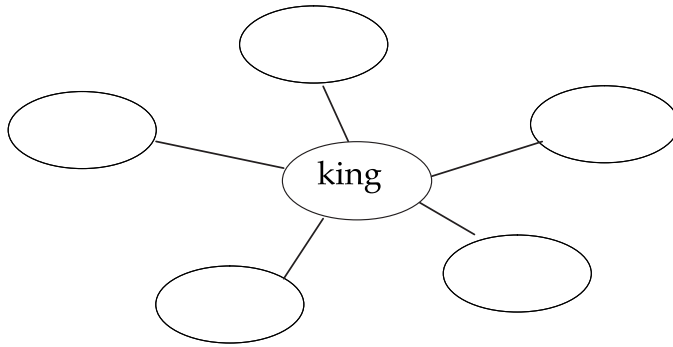

Q6. Fill in the missing letters.

i) Que_n

ii) Sum__r

iii) Bef_re

iv) R_g_l_r

v) P_op__le

Q7. Write the meanings of following words in Hindi.

Guilty, dream, curious, wind, leave, again, nice, punish, hurry, world

Q8. Answer the following questions.

i) Why did the king wear the wig and the crown?

ii) Who made the tants?

Q9. Make new words.

Br
F
S

ought

S
L
T

ong

B
S
L

ad

K
R
S

ing

G
W
M

ood



Lesson - 6

From a Railway Carriage

Q1. Match the rhyming words.

- | | |
|--------------|---------|
| i) Road | battle |
| ii) River | load |
| iii) Witches | forever |
| iv) Cattle | plain |
| v) Rain | ditches |

Q2. Fill in the blanks with the given words

Wink, battle, fairies, glimpse, through

- i) _____ are imaginary things or person.
- ii) Once I was passing _____ the dense forest
- iii) After a long _____ we got freedom
- iv) The thief went out of sight in the _____ of an eye.
- v) We saw a _____ of the moon in a cloudy night

Q3. Write the meanings in Hindi

Fairies, meadows, cattle, cart, witches

Q4. Write five means of transport.

Q5. Write true or false.

- i) The train is faster than fairies and witches. (_____)
- ii) There is no bridge or river in our way. (_____)
- iii) The child clambers and scrambles. (_____)
- iv) Here is a tramp who stands and gazes. (_____)
- v) Here is the cart that rar away in the river. (_____)

Q6. Match the following



Boat



Bullock cart



Train



Bus



aeroplane

Q7. Complete the missing words from the given words.

Witches, hedges, faster, houses, charging

_____ than fairies, faster than _____ bridge and _____, _____ and ditches and a long like troops in a battle.

Q8. Write one rhyming word for each.

- i) Road _____
- ii) River _____
- iii) Witches _____
- iv) Cattle _____
- v) rain _____

Q9. Make new words

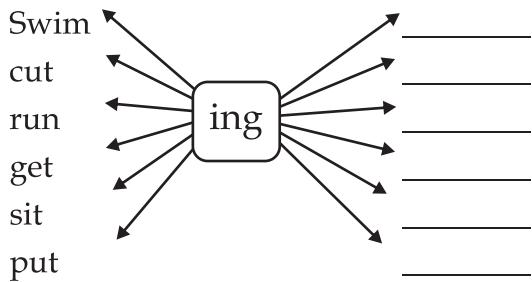

Q10. Separate the root word with the given words.

S.No	Word	Root word
1	Charging	Charge
2	Fairies	
3	Driving	
4	Stringing	
5	Daisies	
6	gathering	

Q11. Answer the following questions

- i) What does the railway carriage (train) move faster than?
- ii) How do the fast moving bogies look like?

Q12. Make new words

- Clean cleaner
- Strange _____ soft _____
- warm _____ old _____
- strong _____ clean _____
- strange _____ soft _____
- warm _____ old _____
- strong _____

Q13. Separate these words.

Tree, pen, bottle, ant, lion, bag, man, table, parrot, book

Living	Non living

Q14. Separate these things

Tree, slop, bird, animal, tower, forest, bees, pen, ant, fish

Moving	Stationary

Q15. Read the paragraph carefully and pick out the naming words (noun)

Sheela was traveling by bus. She came across shop. She got down near a red light, purchased a mobile and went home.

Q16. Pick up the words from the box and write them with the correct vehicles.

Compartment, petrol, brakes, berth, steering wheel, engine, platform, wheels, bonnet, tyres, stations, gears.

Train _____, _____, _____, _____
Bus/car _____, _____, _____, _____

Q17. Complete the word web with the words related with "railway station".

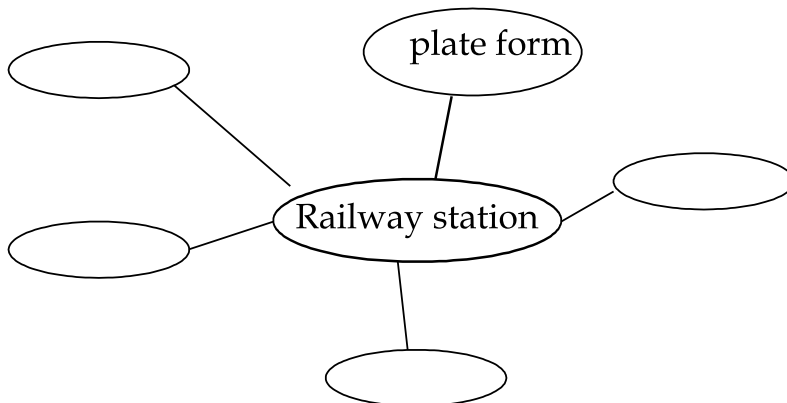

Q18. Write the names of five things which you see during a train/bus journey.



Lesson - 7

Everyday heroes

Q1. Write one word that describes profession after reading the clues.

Chef, playback singer, business man, manager, webmaster, rag-picker, doctor

- i) One who treats is a patient _____.
- ii) One who takes care of a firm/office _____.
- iii) One who runs a business _____.
- iv) One who sings for films _____.
- v) One who designs an internet site _____.
- vi) One who cooks in a hotel _____.
- vii) One who collects waste _____.

Q2. Answer the following question.

- i) Why is Naranbhai Karangia called the “peacock doctor”?
- ii) How did the singer “Abhijit” help the couple and the accident victim?
- iii) Why does Vasant Kalbag promote “kindness” among people?
- iv) How was Amala Mary able to prevent the rail tragedy?
- v) What is the Kalpana Chawla award given for?

Q3. Write true or false.

- i) Karangis sets up centres where birds are looked after and fed.
- ii) “I hate peacocks”, says Karangia.
- iii) Abhijeet Bhattacharya is a hindi actor.
- iv) Abhijeet says “Don’t waste your time to help road accident victims.”
- v) Vasant Kalbag discourages people to become king.
- vi) Help others it boosts our health and longevity.
- vii) Kalbag delivers lectures to school and college students on the importance of kindness.
- viii) Green and lovely lane is a model project that attracts urban experts from around the world.
- ix) Amala started running on the embankment towards the train.
- x) The driver applied the emergency brakes and stopped the train.

Q4. Some acts of the ‘heroes’ in the lesson are given below. Explain the result of their timely action.

S.No.	Step taken	Result
1	Setup centers in villages for birds	
2	Instructed driver to take the injured man to hospital	
3	Encouraged people to be kind	
4	Implementation of Area Locality Management	
5	Stopped the train	

Q5. Select the phrases from the box and write what you enjoy (do not enjoy doing.)

Example- (i) I enjoy playing with dolls.

Playing with dolls, making kites, flying paper planes, floating paper boats, climbing up trees, teasing puppies, plucking flowers, drinking milk, painting picture, making faces, miming, pulling tails of cats, taking bath in cold water, studying, going to school, cleaning house, polishing shoes, doing home work, writing, painting, cooking food.

Q6. Answer in one word and use clues given.

- i) White colour, long tail, eats mice. What am I?
- ii) Tallest mountain, very cold situated in Nepal. Who am I?
- iii) Ship of the desert, can live without water for up to a month. Who am I?
- iv) Small in size, we hear music on it. Children like listening to it. What is it?
- v) I go from house to house and deliver letters. Who am I?

Q7. Write the meaning of the word in Hindi

farmer, devoted, wild, scarred, gather, peacock, injure, unconscious, couple, crowd, immediately, reluctant, hesitate

Q8. Write the missing letters.

- | | | |
|-------------------|-----------------|-------------|
| i) M__n__g__m__nt | ii) S__p__r__te | |
| iii) V__r__e__y | iv) P__i__r__ty | v) A__o__nd |

Q9. Rearrange the letters to make meaningful words.

- i) Gbarage _____
- ii) Cpmosot _____
- iii) Veintay _____
- iv) Rirugee _____
- v) erepxt _____

Assignment-

- Write ten lines about your chief minister.

Scrap book

- Draw or paste the picture of your chief minister, prime minister, president of India



Lesson - 8

At School

Q1. Fill in the blanks using the clues.

- i) Govinda _____ late to class. (come)
- ii) Last year, we _____ cricket every Saturday, but now we have classes on Saturdays (play)
- iii) In the past years, people _____ to theaters for watching movies. Now they view movies through CDs. (go)
- iv) When I was a child, I never _____ tea or coffee, but now I take both. (drink)
- v) He _____ music when he was young. (learn)

Q2. Here are some sentences. Frame questions with the help the words from the list given below. One is done for you.

what, where, when, why, how

Example- I left home at 8 pm.

When did you leave home?

- i) I arrived at Baster at 9 am.
- ii) The match began at 11 am.
- iii) The class for the day ended at 5.30 pm.
- iv) We bought a gift for my friend's birthday at 6 pm
- v) We went to the market by taxi.
- vi) The taxi driver charged Rs1000/- for finding a hotel.

Q3. Write true or false.

- i) Mahatma Gandhi used to be very shy and avoided all company. (____)
- ii) Both Harish Chandra and Shravana are non living realities for me. (____)
- iii) I had the true notion that gymnastics had nothing to do with education. (____)
- iv) Good hand writing is a necessary part of education. (____)
- v) My books and my lessons were my sole companions. (____)

Q4. Write the meanings in hindi

recollect, avoid, belonging, deceive, intense, mediocre, afraid, memory, purchase, pilgrimage

Q5. Match the columns

Mental	stale
Good	answer
Discipline	untouched
Remember	wrong
Like	wrong

Question	physical
Fresh	unnecessary
Touch	indiscipline
Right	forget
Necessary	dislike
Perfect	bad

Q6. Answer these questions.

- i) How did the book and picture of Shraavan affect Gandhiji?
- ii) Why did Gandhiji weep piteously?
- iii) What was the wrong notion that he had?
- iv) Why Mahatma Gandhi completed his homework?
- v) Why good hand writing is a necessary part of education?

Q7. Make new words-

Carry	_____
Pay	_____
Belong	_____
Read	_____
travel	_____
connect	_____
reach	_____
avoid	_____
dislike	_____
touch	_____

Assignment-

- Write about Subhash Chandra Bose.

Scrap book-

- Draw or paste the picture of Lal Bhadur Shastri, Sardar Vallab Bhai Patel, Mahatma Gandhi.

Portfolio-

- Draw a portrait of Chandra Shekhar Azad



Lesson - 9

Beats in Memoir

Q1. Write the meaning in Hindi

Heritage, showcase, commitment, several, continue, legacy, prime, discharge, span, costume, individual, popular

Q2. Answer the following question.

- i) What is Devdas Banjare famous for?
- ii) How did Banjare get exposed to Panthi?
- iii) Which community is famous for its Panthi tradition?
- iv) Name some popular 'mudras' in Panthi.
- v) Why does the community cherish the dance form so much?

Q3. Fill in the blanks

Energy, mandhar, Charandas, chor, Shyam Benegal, Guru Ghasidasji, Phool Singh Banjare

- i) Devdas Banjare has acted in the film _____ by _____
- ii) The dancers _____ is very important in panthi.
- iii) The satnami's regard _____ as their Guru.
- iv) _____ raised Banjare as a child.
- v) Instruments such as the _____ accompany the artistes in their performance.

Q4. Add suffix 'ed', 'en' and make new words-

Acknowledge, discharge, sustain, expose, raise, strength, play, encourage, display, fright, taste, start, fix, awake, surprise

Q5. Make your own sentences using following words.

dance, perform, new, role, county

Q6. Write the missing letters.

- i) H_n_ur ii) _nv_c_ti_n iii) Instru__nt
- iv) _v_r v) G_d

Q7. Answer the following questions.

- i) What is Panthi?
- ii) Who was Devdas Banjare?
- iii) What is 'Mudra'?
- iv) Panthi belongs to which community?
- v) Which film did Banjare act in?
- vi) When was Devdas Banjare born?

Q8. Write true or false.

- i) Chhattisgarh is famous for panthi dance. (____)
- ii) The panthi dance belongs to Brahmin Community. (____)

- iii) The dancers perform few Mudras. (____)
- iv) Devdas Banjare died in a car accident. (____)
- v) Banjare's commitment to panthi was unparalleled. (____)

Assignment-

- Complete the Bio-data of Devdas Banjare
Name
Father's name
Date of Birth
Place of birth
Work experience
Awards received
- Write the similarities and dissimilarities about Tejan Bai and Devdas Banjare.
- Describe any dance form of your local area. Write about it- costume, Mudras and musical instruments used in the dance performance.
- Write one paragraph about 'Dances' in your own words.

Scrap book-

Collect the picture of Tejan Bai and Devdas Banjare and paste it.



Lesson - 10

A place fit for Gods to Marry

Q1. Match the following with opposite words-

- | | |
|--------------|-----------|
| i) Fit | village |
| ii) City | new |
| iii) Married | unfit |
| iv) Old | many |
| v) Some | unmarried |

Q2. Fill in the blanks

Madurai, Sundereswara, Tamil Nadu, myth

- i) There are hundreds of stories about _____ -
- ii) One of the other _____ about Madurai.
- iii) Madurai is in _____ state.
- iv) Goddess Meenakshi's husband is _____

Q3. Write the word meanings in Hindi

chariot, nectar, poison, myth, pillar, melody, ido, venom, crescent, turn, strands, splendor

Q4. Write the missing letters.

- | | | |
|-----------------|----------------|---------------|
| i) Ma_nifi__ent | ii) C_lebr_t_d | |
| iii) N_utr_l_z_ | iv) M_th | v) P_l_n_qu_n |

Q5. Answer the following questions

- i) What was Madurai earlier known as?
- ii) Why is Madurai called the city of nactor?
- iii) Why did Shiva put nector on Madurai?
- iv) What do you like most about Madurai?
- v) How many legends about Madurai have you read in the lesson?
- vi) Which of the legends about Madurai do you find the most interesting? why?
- vii) Which type of structure has Meenakshi's temple?
- viii) Is Madurai New city to Tamil nadu?

Q6. Tick mark the correct option given below-

- i) Melodious

(a) Sad	(c) musical	(b) Merry	(d) happy
---------	-------------	-----------	-----------
- ii) Neutralize

(a) To be filled with nector	(b) To make something harmless
(c) Finish the value	(d) To make something look beautiful

- iii) Venom
 (a) poison (c) money (b) blessing (d) honey
- iv) Nectar
 (a) Beauty (c) poison
 (b) Drink of Gods (d) bright light from heaven
- v) Ancient
 (a) New (c) old (b) Attractive (d) huge
- vi) Attack
 (a) To harm someone (c) to be friendly with someone
 (b) To argue with someone (d) to be angry with someone
- vii) Summon
 (a) Tell someone to come of court (c) tell someone to salute
 (b) Tell someone to speak of you (d) tell someone to sum up
- viii) Magnificent
 (a) Grand (c) interesting (b) Ordinary (d) bright

Q7. Make new words

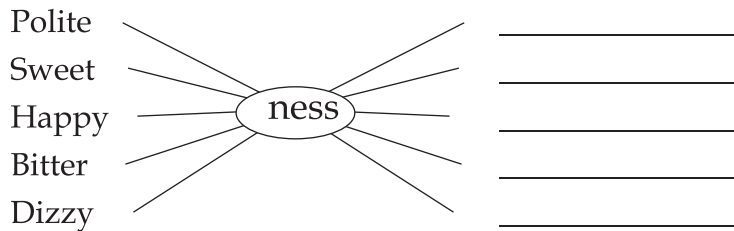

Q8. Match the adjectives with their opposites

- | | |
|--------|-----------|
| Polite | beautiful |
| Sweet | rude |
| Bright | dull |
| Neat | bitter |
| White | dirty |
| Ugly | black |

Q9. Make sentences

tall, angry, huge, nice, horrible, strange, wonderful, beautiful, rose, sweet

Assignment-

- Write ten lines about an elephant in your own words.
- Write about any one city which you like.

Scrap book-

- Collect the picture of old temples and paste here.
- Collect different tourist places and paste here.



Lesson - 11

Sympathy

Q1. Answer the following questions.

- i) Who is the poet of this poem?
- ii) What was the girl's feeling about the little bird?
- iii) What did the little bird feel about the little girl?

Q2. Match the opposite words.

- | | |
|-------------|--------|
| i) Thin | group |
| ii) Little | sunset |
| iii) Girl | fat |
| iv) Cold | boy |
| v) Sunrise | big |
| vi) Without | group |
| vii) She | hot |
| viii) Out | with |
| ix) Single | in |

Q3. Write the meanings in Hindi

plump, mine, meadows, weather, must, feather, sunshine

Q4. Make new word.

Weath		weather
Show		_____
Togeth		_____
Shiv		_____
Feath		_____

Q5. Tick ✓ the correct sentences and x the wrong sentences.

- i) The little bird was covered with feathers. (_____)
- ii) They shivered due to the cold weather. (_____)
- iii) It was sunny weather. (_____)
- iv) The girl is thin and the bird is plump. (_____)
- v) The little girl and the little bird were out in the meadows. (_____)
- vi) The weather was rainy and cloudy. (_____)
- vii) Without any clothes like mine, said she. (_____)

Q6. Complete the poem with the help of given words.

girl, thin, bird, meadows, cold, poor, mine, weather, sunny

A plump little _____ and a _____ little _____ were out in the _____ together.

How ___ that _____ little _____ must be without any clothes like _____ said she although it is _____.

Q7. Write the missing letters

- | | | |
|--------------|--------------|----------------|
| i) M__d__ws | ii) C__ld | iii) S__nsh__y |
| iv) W__ta__r | v) Pl__p | vi) Si__gl__ |
| vii) B__d__ | viii) M__n__ | ix) Fea__h__r |

Q8. Tick ✓ the naming words and the describing words

- | | | |
|----------------|--------------------|--------------------|
| i) Little girl | ii) Single feather | iii) Weather |
| iv) Poor thing | v) Meadows | vi) Cotton clothes |
| vii) Black rat | viii) board | |

Q9. Make your own sentences using words given below-

plump, poor, thin, nice, sunshine, fat, little, how

Q10. Fill in the blanks with the help of 'is', 'am', 'are'

- | | |
|------------------------------|----------------------------|
| i) This _____ a book. | ii) We _____ good friends. |
| iii) I _____ a boy. | iv) These _____ pencils. |
| v) I _____ a cricket player. | |

Q11. Some food items are given below. Write their shape, size, taste, look, colour. Do you like or dislike it?

Jalebi, Roti, Samosa, Gulab Jamun, Dahi Bada, Kheer

Assignment -

- Write the poem Sympathy.
- Write few lines about Rain,
- Write the names of five birds, reptiles and pet animals.

Scrap book

- Paste the picture of house.
- Collect the pictures of a bird, a girl, a tree, a clothes, a dog, a lamb and paste it.



Lesson - 12

Children Ask Kalam

Q1. Answer the following questions.

- i) What is the full name of Abdul Kalam?
- ii) Who was the best friend of Kalam in school time?
- iii) Write two questions which were asked by children to Dr. Kalam?
- iv) Describe Kalam's happiest day.
- v) What is courage according to Dr. Kalam?
- vi) What suggestion does President Kalam give to children for remembering formulas of Science?

Q2. Write the meanings in Hindi.

fortune, pedding, bliss, secret, bravery, orbit, ensure, corruption, gravity, spirit, etched, disaster, application

Q3. Make new words

Founda		_____
dedicat		_____
addict		_____
corrupt		_____
applied		_____

permanent		_____
proud		_____
mental		_____
physical		_____

gambl		_____
suffer		_____
accord		_____

Q4. Add 'ed' and change into past tense.

Challenge, change, celebrate, play, create, appoint, complete, remained, end

Q5. Do as directd

- i) I know, he is a typist. (use of that / then)
- ii) He is my friend, he knows everything about me. (use of and / but)
- iii) I go to market, I will bring chocolates. (use of if / then)

Q6. Select the appropriate word to complete the sentence.

- i) Abdul Kalam is an _____ to young people. (achievement / inspiration)
- ii) Teacher's play an important part in _____ children's interest in subject. (forcing /

shaping)

- iii) The Defence Research and Development organization _____ a lot of Scientists.
(employs / arrests)
- iv) It is important for children to develop their _____(personalities / brains)

Q7. Match the following clues are given to help you to complete proverbs.

Tiny drops make (search for water)	make more noise
A stich in time (search for number)	mightier than the sword
An apple a day (search for a profession)	mo not bite
Empty vessels (search for noise)	a mighty ocean
The pen is (search for weapon)	saves nine
Failure is the (search for achievement)	keeps the doctor away
Barking dogs (search for what dog do)	is the best policy
Make hay (search for planet)	stepping stone to success
Honesty (end with 'ey')	while the sun shines
A friend is need (rhymes with 'friend')	is a friend indeed

Q8. Complete the words with 'ea' or 'ee'

- i) ___rly, ii) sw___t, iii) h___lthy,
- iv) f___t, v) t___th, vi) w___lhy,
- vii) r___d, viii) s___t, ix) Ch___ks,
- x) gr___n

Assignment-

- Identify five proverbs in your local language.
- Write about Dr. Abdul Kalam.
- Write a five lines about fever and cold in your own words.

Scrap book-

- Collect the pictures of bathing, playing, brushing and paste it.
- Paste the picture of Dr. Abdul Kalam.



Lesson - 13

Sayani

Q1. Given the list of some words, use 'ity' and make new words.

Suitable, pure, sure, grave, able, capable, comparable, accountable, teachable

Q2. Answer the following questions.

- i) What is the ISI mark used for?
- ii) Why should we buy packaged spice?
- iii) How can you know that the gold you are buying is pure?
- iv) Why is the slogan 'Jago Grahakk Jago' used?
- v) What are the benefits of purchasing ISI mark?

Q3. Do as directed? Use the names of the students in place of he/she.

Example- who could help me to stitch a frock?

Response: I can stitch a frock.

He said, 'he can stitch a frock'.

He said that he could stitch a frock.

- | | |
|--------------------|----------------------|
| i) Mend my shoes. | ii) Make a table. |
| iii) Cut the grass | iv) Fly an aeroplane |

Q4. Write the meanings in Hindi

aware, consumer, recognize, insist, harmful, loose, contain, synthetic, spice, ignore

Q5. Make rhyming word

- | | |
|--------------------------|-------------------------|
| i) May = _____, _____ | ii) Sold = _____, _____ |
| iii) Pure = _____, _____ | iv) Test = _____, _____ |
| v) Fire = _____, _____ | |

Q6. Rearrange the letters to make meaningful words

- | | | |
|-------------|------------|----------|
| i) Buaces | ii) Cluro | |
| iii) Hlaeth | iv) Wneinr | v) tiehr |

Q7. Write the missing letters

- | | | |
|------------|----------------|---------------|
| i) P_i_e_ | ii) A_s_l_t_ly | |
| iii) P_re_ | iv) S_m_ol | v) C_m_l_te . |

Assignment-

- Write about jewellery shop

Scrap book-

- Draw or paste the pictures of -
Toothbrush, toothpaste, tongue, cleaner, table fan, pressure cooker

Portfolio

- Draw the picture of a ceiling fan, neckless, table lamp



Lesson - 14

Craze

Q1 Write true or false in the given space.

- i) The patient grows restless and starts rushing to the travel agent. (_____)
- ii) Travelling increases knowledge. (_____)
- iii) 'travelia' the modern disease of the rich. (_____)
- iv) The disease mentioned in the lesson is not infectious. (_____)
- v) The seasonal outburst can be seen during the summer vacations. (_____)
- vi) The German and British are fond of taking photographs of themselves before places of historical interest. (_____)

Q2. Answer these question.

- i) What is 'travelia'?
- ii) Who falls prey to it?
- iii) Why do people feel anxious to contact travel agents?
- iv) When do we see the seasonal outburst?
- v) Research is still required on two things. What are they?

Q3. The names of diseases are given categories them in the table given below.

malaria, cancer, paralysis, small pox, cholera, typhoid, pneumonia, AIDS, jaundice, T.B, polio, diarrhea

Infectious disease	Non-infectious disease

Q4. Complete the sentences with one of the word given in the brackets.

- i) Our _____ in the staff made a plan to visit Agra this week. (colleague, neighbor)
- ii) Scientists are trying to discover a vaccine for a _____ called AIDS. (disease, pneumonia)
- iii) The Red Fort, Jantar Mantar and Taj Mahal are _____ (monuments, museums)
- iv) 'Travelia' is a modern disease. People living in _____ full prey to it. (urban area, rural area)
- v) The disease mentioned in the lesson is (infectious, serious)

Q5. Give one word for the following expressions.

- i) One who is sick. He is a _____
- ii) We can get it from a newspaper radio and T.V _____
- iii) It is the opposite of 'familiar' _____
- iv) The place where we can see old things. _____

Q6. Make your sentence from the table given below

I We You They He She Ramu	have seen has seen	Sirpur Kanger valley Bhoram Dev Sonakhan Mainpat Chi trakot fall
---	---------------------------------------	---

Q7. Write the meanings in Hindi

Disease, spread, tendency, attract, observe, eager, actually, appearance, concession, affectionate

Q8. Rearrange the letters

- | | | |
|--------------|--------------|-----------------|
| i) satpmym | ii) aeixtny | iii) aitntapcie |
| iv) munonemt | v) aitnethuc | vi) htatisec |
| vii) afrafd | | |

Q9. Write the missing letters.

- | | | |
|--------------|--------------|-------------|
| i) P_o_le | ii) E_i_e_ce | iii) T_a_el |
| iv) Q_e_t_on | v) R_s_a_ch | |

Q10. Match the column

- | | |
|---------------|-------------|
| i) Start | initial |
| ii) Fast | dis-satisfy |
| iii) New | spend |
| iv) Final | in |
| v) Take | end |
| vi) Big | slow |
| vii) Eat | old |
| viii) Satisfy | give |
| ix) Save | small |
| x) Out | drink |

Q11. Circle the odd one

- | | |
|-------------------------------|----------------------------|
| i) Root, foot, must, shoot | ii) Bug, hug, mug, fuse |
| iii) Much, such, catch, touch | iv) Same, some, game, same |
| v) Cook, cock, look, book | |

Assignment-

- Write about any journey.
- Write about any historical place.

Scrap book-

- Draw or paste the picture of ---- Taj Mahal, Red Fort, Kutubminar, Gate way of India

Portfolio- Draw a picture of beach, mountain, desert



Lesson - 15

The Birdman of India

Q1. Fill in the blanks with the appropriate words given below.

Winged bipeds, reptiles, ornithology, budding, intervention, laboratory, identified

- i) His _____ saved the Bhartpur bird sanctuary.
- ii) Dr. Salim Ali studied the life of birds in natural conditions not in the _____
- iii) The science of studying bird is known as _____
- iv) The secretary _____ the sparrow as the yellow throated sparrow.
- v) Animals that are able to change blood temperature and usually lay eggs are _____
- vi) 'The book of Indian Birds' is a bible for _____ ornithologists.
- vii) Birds are called _____

Q2. Match the column

- | | |
|----------------|---|
| 1 Ecology | Given as an honor and not according to the usual rules. |
| 2 Deities | Those who are not experts |
| 3 Conservation | Flowers, animals, birds in the environment |
| 4 Amateur | Images that we worship |
| 5 Honorary | Attempt to save natural resources |

Q3. Frame your own sentences using the word/ phrases.

High attitudes, distant objects, nature lover, life master

Q4. Answer the following questions.

- i) Why is Salim Ali called the Birdman of India?
- ii) What do 'feathers of birds tell us'?
- iii) 'Looking at the beak of bird, it is possible to understand its life cycle'. Explain.
- iv) What influenced Salim Ali to become an Ornithologist?
- v) Why do people worship nature?

Q5. Write the meanings in Hindi

Ancestor, ecology, exist, wing, constant, feather, orphan, reptile, splendid, legacy

Q6. Make new word adding 'ing'

Worship, observe, destroy, hum, interesting, hear, adjust, run, include, travel, bud

Q7. Make new word using 'ion'

Situate, habitat, destruct, dedicate, contribute

Q8. Circle the odd one

- i) Tree, tire, free, shree
- ii) Face, guess, trace, less
- iii) Sight, that, right, might
- iv) Food, good, mad, mood
- v) Keen, seen, lean, rin

Q9. Write true or false

- i) Birds are called winged bipeds. (_____)
- ii) The body temperature of birds remains more or less constant. (_____)
- iii) Birds have the wonderful capacity of adjusting their vision late. (_____)
- iv) Humming bird is one of the largest species of birds. (_____)
- v) Ostrich is the smallest bird on the planate. (_____)

Assignment-

- Describe your favorite bird by completing the table given below.

Name of bird	Picture	Colour	Sound Tail	Special feature

Scrape book

- Draw or paste the picture of humming bird, ostrich, kiwi, eagle, hawk, emu

Portfolio-

- Draw a picture of Eagle or Parrot.



Lesson - 16

The Mountain and Squirrel

Q1. Tick ✓ the correct answer.

- i) The quarrel between the mountain and the squirrel was about-
- (a) Length (c) size
(b) Ability (d) strength
- ii) The mountain is able to
- (a) Carry a forest (c) crack a nut
(b) Make a spry movement (d) make up a year
- iii) The squirrel is able to
- (a) Make a sphere (c) crack a nut
(b) Make up a year (d) carry forests
- iv) What is the meaning of 'crack'?
- (a) To break open (c) to argue
(b) To bring shame (d) refuse to accept
- v) 'Prig' means-
- (a) Length (c) size
(b) Ability (d) someone who is very careful about rules

Q2. Find out the meaning of these phrases and make sentences.

- i) Little Prig.
ii) All sorts of things.
iii) Make up a year.
iv) Occupy my place
v) All is well

Q3. Answer the following questions

- i) Why does the mountain call the squirrel 'little pig'?
- ii) What qualities of the mountain does the squirrel appreciate?
- iii) What tasks is the mountain unable to perform?
- iv) Do you like the squirrel's reasoning? Why?

Q4. Match the following

Quarrel	without doubt
Doubtless	special ability
Disgrace	refuse to accept
Deny	to argue
Talent	to bring shame

Q5. State true or false

- i) The mountain is able to carry a forest.
- ii) The squirrel is able to crack a nut.
- iii) The mountain and the squirrel had a quarrel
- iv) The mountain is able to crack a nut.
- v) The squirrel is able to carry a forest.
- vi) Q6. Fill in the blanks with the words given in the bracket.
- vii) The giraffe is _____ (tall/ taller) than the elephant.
- viii) The elephant is _____ (havier / heavy) than monkey.
- ix) The tiger is _____ (fast / faster) than elephant.
- x) The tortoise is _____ (big / bigger) than an ant.

Q7. Fill in the blanks

Mountain, doubtless, big, former, replied

- 1) The _____ and the squirrel had a quarrel.
- 2) And the _____ called the latter 'Little Prig'.
- 3) Bun _____
- 4) You are _____ very _____

Assignment-

- Write the four lines of the poem- 'The Mountain and the squirrel'
- Write a paragraph to describe an animal or a bird they you find attractive.

Portfolio

- Describe the poem in your own word.
- Draw a scene of mountain and squirrel from the lesson.



Lesson - 17

Nothing but the Target

Q1. Match the following

Absolutely	to succeed in doing
Wrap	covered or decorated with cloth
Draped	completely and definitely
Target	to cover something
Accomplish	a result that you try to achieve

Q2. Fill in the blank with the words given.

Proud, great, feels, good, medal

It felt absolutely _____. It certainly _____ good to win a _____ for the country. And that makes it even more _____ because the country feels _____

Q3. Choose the correct answer

- i) The 28th Olympic games were held in-

(a) Sydney	(c) Seoul
(b) Athens	(d) London
- ii) How did he feel when he received the silver medal?

(a) Absolutely great	(c) happy
(b) Sense of relief	(d) sense of pride
- iii) When I felt that I was getting anxious I would -

(a) Sing a song	(c) smile a bit
(b) Think of the target	(d) relax, crack a joke and talk to somebody
- iv) Rajyavardhan Singh Rathor won silver medal for India in which event

(a) Table tennis	(c) badminton
(b) Athletics	(d) shooting event
- v) 28th Olympic games was held in year-

(a) 2001	(c) 2003
(b) 2004	(d) 2002

Q4. Answer the following questions

- i) What is special about Rajyavardhan Singh Rathore winning the silver medal in shooting?
- ii) What makes the country feel proud.?
- iii) Why did he wrap the country's flag around himself at the presentation?
- iv) What would he do whenever he needed to focus on the spot?
- v) Why is aggression important in a spot?

Q5. Match the following

Kabirdham	Jain temple
Champaran	fall
Kutumsar	Danteshwari temple
Chitrakoot	Bhoramdev mandir
Dantewada	caves
Bhaichung Bhutia	Atheletics
Sania Mirza	cricket
P.T.Usha	chess
Sachin Tendulkar	football
Viahwanath Anand	Tennis

Q6. Use the words given below in your sentences

accomplish, aggression, target, draped, medal

Q7. Make new word adding 'ly'

automatical, love, kind, absolute, certain

Assignment-

- Make a list of famous sports person in your locality and describe why you admire them.

Portfolio-

- Paste picture of five sportsman.



Lesson - 18

Dancing on

Q1. Choose the correct answer.

- i) While performing, sudhir wore-----
 - (a) Modern costume
 - (b) Traditional costume
 - (c) Western costume
- ii) She worked for the film
 - (a) Nacha Mayuri
 - (b) Arunima
 - (c) Gajagamini
- iii) Before Sudha was 17 years of age, she had given ___ performance
 - (a) More than 70
 - (b) More than 80
 - (c) Less than 80
- iv) Sudha made a historic come back on -
 - (a) 15 october 1983
 - (b) 1 January 1982
 - (c) 28 january 1984
- v) Sudha Chandran was inspired by-
 - (a) Helen Keller
 - (b) Elena John
 - (c) Valentiana Tereskova

Q2. Write true or false

- i) In a road accident Sudha lost her right hand.
- ii) She again came back with her new dance item.
- iii) She hasn't worked in any film.
- iv) She has given performances only in foreign countries.
- v) People wrote that they were not inspired by her success stories.

Q3. Answer the following questions.

- i) What were the strange words introduced to the audience in Washington?
- ii) What did Sudha always do before her performance?
- iii) Why did Sudha lose her leg?
- iv) Why did Sudha say, "My dream will come true." When she met Dr. Pramod?
- v) What was turning point in Sudha's life?
- vi) Sudha Chandran says towards the end to the lesson, "I do feel thrilled"? identify why she feel so?
- vii) How did Sudha get the opportunity to act in films?
- viii) Who was Sudha Chandran?
- ix) Who inspired Sudha Chandran?
- x) Name Sudha Chandrans first hindi film?

Q4. Make a word list related to given word-

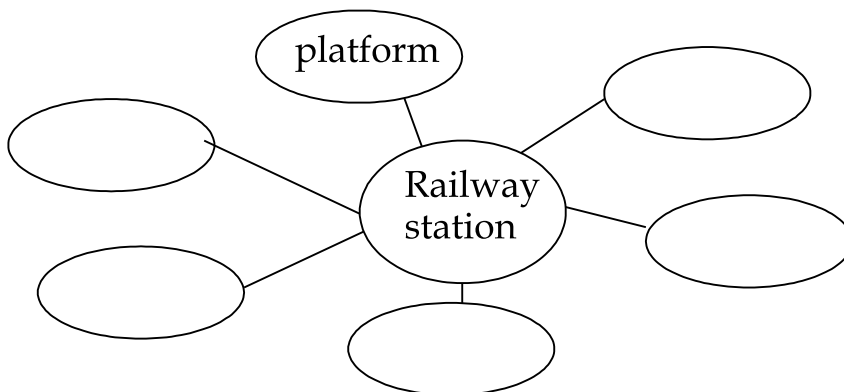
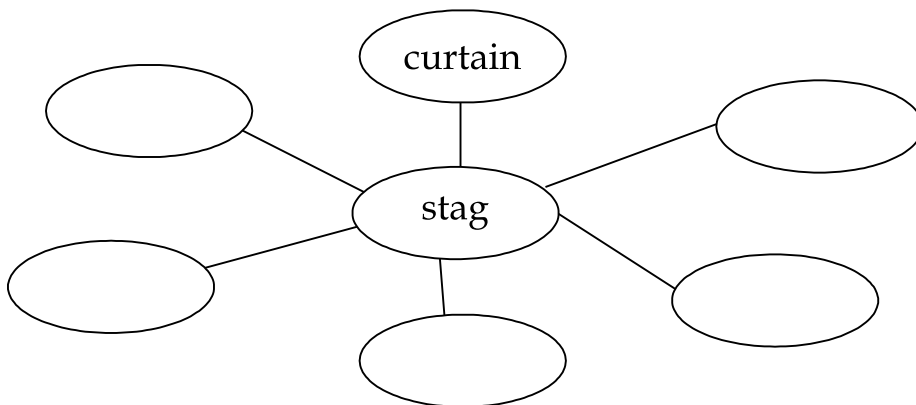
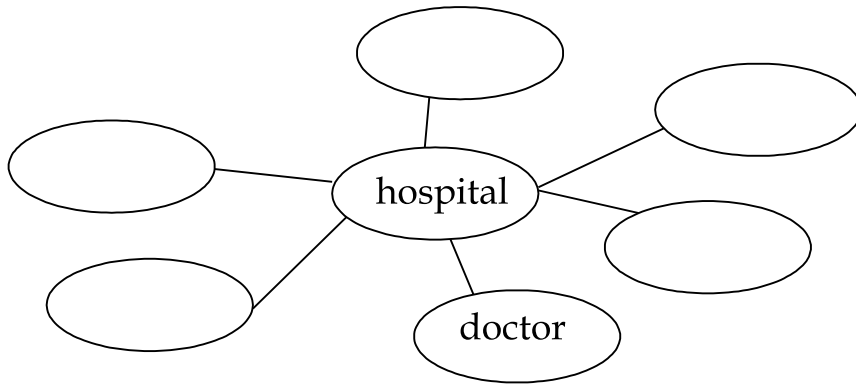

Q5. Fill in the blanks with the given words

Defeats, amputate, historical, miracle, costume

- i) Rashmi wore a new _____ for the party.
- ii) Rahim was injured and the doctor were forced to _____ his right hand.
- iii) I visited many _____ places in India.
- iv) The Indian team _____ the South African team in the hockey match.
- v) It is only a _____ that Seema once again is able to see this beautiful world.

Lesson - 19

Dear Daddy – Long Legs

Q1. Tick the correct answer

- i) J. A is used for-
- | | |
|------------------------|----------------------|
| (a) Jerusha and Abbott | (c) Jerusha Abbott |
| (b) Jean Abbott | (d) Jean and Jerusha |
- ii) Jerusha Abbott is a
- | | |
|-----------------------|-------------------|
| (a) A bald man | (c) a naughty boy |
| (b) An orphan student | (d) a farm girl |
- iii) Mrs Loppett may be
- | | |
|------------------------|---------------------------------|
| (a) Jerusha's mother | (c) incharge of John Grier Home |
| (b) Teacher of Jerusha | (d) wife of Daddy long legs |
- iv) 'Are you bald'? is written for :
- | | |
|---------------------|--------------------|
| (a) John Grier | (c) Mrs Lippett |
| (b) Daddy long legs | (d) Jerusha Abbott |
- v) John Grier Home
- | | |
|--------------------|-------------|
| (a) Orphan's house | (c) a farm |
| (b) School | (d) collage |

Q2. Answer in yes/no to following questions.

- i) Is the writer happy to go on a trip to a farm?
- ii) Is the home in the lesson same as your home?
- iii) Does the writer love Daddy Long Legs?
- iv) Has she finished her examination?
- v) Has Daddy Long Legs answered her questions?

Q3. Answer the following questions

- i) What is the promise made in the first letter?
- ii) Why does the writer say that it is not a letter?
- iii) Why is the writer happy to go on a trip?
- iv) Why does the writer say, 'I am going to love being free.'?
- v) What is the name of the home the writer lives in?
- vi) What is the feeling you have for the writer?
- vii) Who is writer of the lesson- 'Dear Daddy Long Legs'?
- viii) What is the meaning of portrait?
- ix) What is the name of the orphans house?
- x) Is the writer happy to go on a trip to a farm?

Q4. Match the following-

Benefactor	catch
Bold	follow
Portrait	who gives money for a good purpose
Chase up	painting
Grab	without hair

Q5. Write bio data of your friend on following heads

i) Name	ii) Age
iii) Hair	iv) Eyes
v) Height	vi) Goes to school by cycle

Q6. Prepare your bio data on following heads

i) Name	ii) Age
iii) Hair	iv) Eyes
v) Height	vi) Class
vii) Number of brother and sisters	viii) School names
ix) Goes to school by cycle	

Q7. Match the following

Springy	quick and full of zest
Tendency	nature
Snappy	comfortable
Satisfactorily	to take decision
Decide	spring like

Q8. Fill in the blanks-

Ever, farm, never, last, three

Happy Day! I have just finished my _____ examination physiology. And now _____ months on a farm! I don't know what kind of a thing a _____ is? I have _____ been on one in my life. I have never _____ looked at one but I know I am going to love it, and I am going to love being free.

Q9. Write a letter to your friend and tell him that you have passed in the examination.**Q10 Write a letter to your father and tell him that you have passed in the examination.****Assignment-**

- Find out in your house an old man / woman whom you like most and write about him/her.

Portfolio-

- Write five lines about your father or mother.
- Write a letter to your friend and tell about your annual function.



Lesson - 20

Fog

Q1. Choose the correct option and complete the sentence.

- i) I saw the fog grow _____
(a) Thick (b) big
- ii) It clutched my throat, I _____
(a) Tougged (b) coughed
- iii) Like balls of burning _____
(a) Tin (b) lead
- iv) Be the heavenly _____
(a) moons (b) stars
- v) a blind man led me _____
(a) town (b) home

Q2. Choose the correct rhyming word of following and put a tick mark on it.

- i) Thick (sick / fit)
- ii) Car (for / star)
- iii) Place (pack / space)
- iv) Head (lead / late)
- v) Child (what / wild)

Q3. Write the stanza number which given the following sense.

- The person reached his home safely with the help of a blind man.
- The man was helpless and was not able to decide where he was.
- It is not possible to see anything during fog.
- He imagines the lights to be like stars.
- The person compares the eyes with burning lead.

Q4. Match the following sentences with their sense

S.No	A	B
1	The person reached his home safely with the help of a blind man	Like balls of burning lead
2	The man was helpless and was not able to decide where he was	Which soon made blind my ken
3	It is not possible to see anything during fog.	I lost all judgment then
4	He imagines the lights to be like stars	Be the heavenly stars.
5	Person compares the eyes with burning lead.	A blind man led me home

Q5. Write true/false against the given statements.

- i) The man was able to see everything in the fog. (_____)
- ii) In the fog, his eyes looked like burning lead. (_____)
- iii) He imagines that the lamps, light and cars are heavenly stars. (_____)
- iv) The blind man help him to cross the road. (_____)
- v) The poet reached his home safely. (_____)

Q6. Match the column

Tall	eyes
Blind	men
Burning	stars
Heavely	my ken
Heavy	lead

Q7. Complete the poem with the help of following words given in the bracket.

giants, blind, fog, tall, thick

I saw the _____grow _____, which soon made _____my ken, it made _____men of boys and _____of tall men.

Q8. Complete the word web

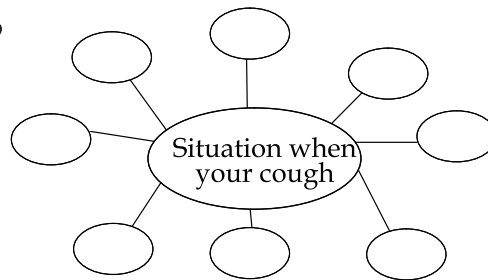

Q9. Write the name of two seasons in which you can see fog.

Q10. Answer the following questions

- i) What does 'I' refer in the poem fog?
- ii) How does the poet's eyes look like in the fog?
- iii) Who was the man who passed by the poet?
- iv) How did the poet reach home?
- v) Which word indicates to us that the second man was blind?
- vi) What message do you get from this poem?
- vii) What looks like heavenly stars?
- viii) What looks like balls of burning leads?
- ix) Why the man lost his all judgment?

Q11. Complete the following spelling.

- I) F_g ii) Ke_ _ iii) _lind iv) C_ utch
- v) L_ st vi) J_ dg_ ent vii) Bur_ ing

Q12. Write the meanings of following words in Hindi.

Fog, ken, blind, judgment, lead, star, heaven, street, thick, stone, heavy, burning, giants, distance

Q13. There are some of the things that visually impaired (blind) people used. Write the use of these things for visually impaired (blind) people and add some more

- i) Cane / walking stick ii) Dark Glasses iii) Tape Recorder

Assignment-

- Write any incident where fog affects visibility
- Write the two rhyming words for each.

Lead, pan, fog, place, dumb, blind, made, light, follow, come, close, car

Portfolio

- Some disabilities are given below. Think about difficulties faced by people with this abilities.



Lesson - 21

The Flavours of Thailand

Q1. Choose the correct option and put a tick mark ✓ on it.

- i) Meaning of 'Thai' word is _____
(a) Freedom (b) kingdom
- ii) Thai gesture of greeting is called-
(a) Hi (b) Wai
- iii) Thailand is bordered by Laos and -
(a) China (b) Cambodia
- iv) In which direction of Thailand Andaman Sea situated-
(a) West (b) South
- v) Thailand's official name till May 11, 1949 was-
(a) Rome (b) Siam

Q2. Write true or false.

- i) Chui Bahadwe was the caretaker of guest house. (____)
- ii) Thailand is situated in South East Asia. (____)
- iii) They went to a cinema hall with Chui Bahadwe. (____)
- iv) Highest peak of Thailand is 'Doi Intharion'. (____)
- v) The Capital of Thailand is Delhi. (____)

Q3. Choose the correct word from the bracket and fill in the blanks

(Bangkok, festival, river, Cuisine, Nampla)

- i) The beautiful Chao Praya _____ runs into the Gulf of Thailand.
- ii) The delicious Thai _____ cooked for us.
- iii) One of the important ingredient is the _____
- iv) We travelled to _____, the capital city

Q4. Match the following columns

- | | |
|------------------|---------------------|
| i) Bangkok | caretaker |
| ii) Chao Praya | Festival |
| iii) Loikrathang | capital city |
| iv) Wai | river |
| v) Chur Bahad We | Gesture of greeting |

Q5. Make new words

- | | | | | |
|--------|---|-------|---|-------|
| Play | \ | (ing) | / | _____ |
| Sing | \ | (ing) | / | _____ |
| Read | \ | (ing) | / | _____ |
| Listen | \ | (ing) | / | _____ |

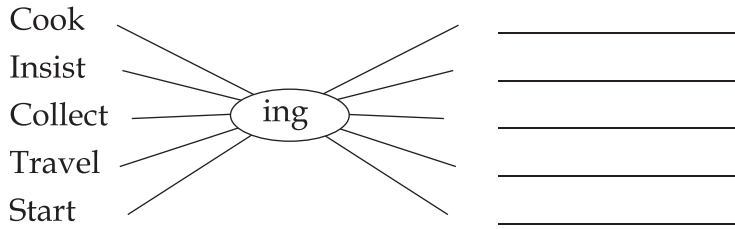

Q6. Write the meanings of following words in Hindi.

Enriching, caretaker, minority, frequent, aromatic, tropical, humid, cuisine, ingredients, climate, tamarind, fortune, guest house, smell, tourist, capital, disappointed

Q7. Write the missing letters and complete the spelling

- i) Me_eu_ ii) Tr_pi_al iii) M_nori_y iv) Fu_lon_
- v) H_m_d vi) Touri_t vii) R_ver viii) In_red_ent
- ix) G_lf x) Sta_da_d

Q8. Choose the correct rhyming word for each and put a tick ✓ on it.

- i) South (mouth / couch) ii) Cold (called / fold)
- iii) River (neck / fiver) iv) Cook (book / take)
- v) Lunch (batch / bunch)

Q9. Complete the phrases with the help of given words.

Cuisine, guesthouse, nature, jasmine, statues

- i) Beautiful Buddha _____
- ii) Neat looking _____
- iii) Delicious Thai _____
- iv) Sweet-smelling _____
- v) Every smiling _____

Q10. Solve the quiz

- i) Four letter word which means Freedom in Thai.
- ii) Thai greeting
- iii) The year 2006 according Buddhist Calendar would 2006 + =
- iv) River that runs into gulf of Thailand
- v) Another name for Intharion is mountain of

- vi) Kra Isthmus flows into peninsula
- vii) Elephants are also called and play in surin

Q11. Use the information given below in box 'A' and 'B' and complete the sentences . use (had + III verb)

A
Reach, leave, finish, make, start, set, take, cut, steal tear

B
Station, the classroom, homework, a doll, lunch, the trees, purse, the sun, the news paper, bath

- i) The children _____ before the teacher came.
- ii) The train _____ at the _____ before we arrived there.
- iii) We _____ our _____ before our father came home.
- iv) My daughter _____ before we come back home.
- v) They _____ before we joined them.
- vi) The _____ before she returned home.
- vii) My father _____ before I got up.
- viii) Someone _____ before the forest guard arrived.
- ix) Someone _____ before the passenger came back.
- x) The baby _____ before his guard father read it.

Q12. Complete the table.

Regular verbs		
I	II	III
Reach	Reached	Reached
Finish	Finished	
	Started	
Look		Looked
	Climbed	

Irregular verbs		
I	II	III
Leave	Left	Left
Make		
Set		
Read		
Steal	stole	

Q13. Write the IInd and IIIrd form of these regular verbs.

Paint, wash, play, appoint, walk, talk, happen, fold, open, point

Q14. Write the IInd and IIIrd form of these irregular verbs.

Take, sing, ring, fly, build, see, give, get, hold, go

Q15. Match the words with their meaning in Hindi

Cucumber	बैंगन
Ginger	लहसून
Chilly	खीरा
Garlic	अदरक
Brinjal	कद्दू

Q16. Consult a dictionary and write the meanings of these word in Hindi.

Cuminseeds, lime, coconut, tomato, fig

Q17. Consult a dictionary and write English word for each spices given below.

Jeera, haldi, haniya, long, kalimirch, methi, rai / sarson, chhoti elachi, kesar, dalchini

Q18. Complete the word web with the names of spices in English/Hindi.

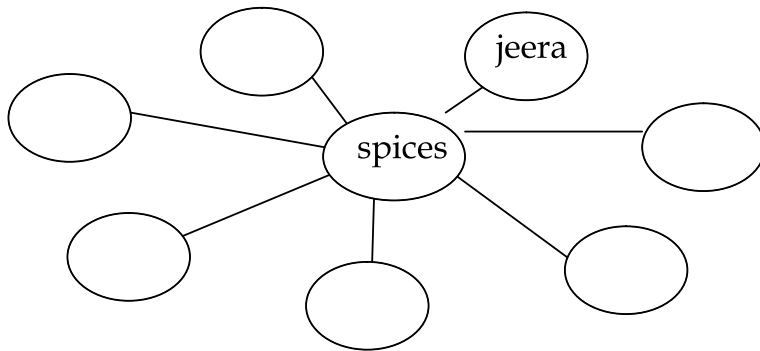

Q19. Look at the picture and match the following



Tomato



Basil



Ginger



Egg plant

Q20. Write the answers of following questions in one word.

- i) Who welcomed at the gate of the guesthouse?
- ii) What is called the Thai gesture for greeting?
- iii) What is the meaning of the word 'Thai'?
- iv) Who is the caretaker of the guesthouse?
- v) Where did they see coins, vessels etc?
- vi) Which is the highest peak of Thailand?
- vii) Where is Thailand situated?
- viii) Which is the capital city of Thailand?
- ix) In which month did they celebrate Loikrathang Festival?

Q21. Write the answer of following questions.

- i) What is interesting about the Thai calendar?
- ii) Write about some famous places in Thailand?
- iii) What is unique about 'Thai' food?
- iv) Write five basic flavours of Thai dishes.
- v) Name some of the important towns in Thailand?

- vi) What happens during the Elephant Round -up?
- vii) Who was Little Doi Swan?

Q22. Complete the word web

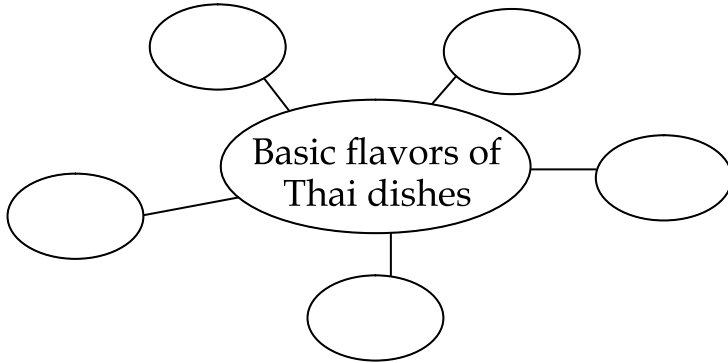

Assignment-

- Write five uses of basil.
- Write five regular and irregular verbs.
- Use the following words in your own sentences.
Neat, ever, sweet, delicious, colourful
- Write five famous places of your state.
- Complete the word web with the name of cuisine of your local area.

Portfolio-

- List the ingredients that go into making the dish. List some instructions on how to prepare the dish.

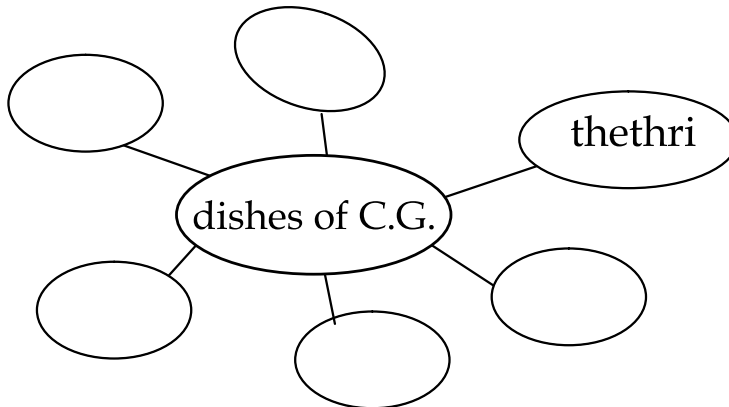

Lesson - 22

The Photograph

Q1. Choose the correct word from the bracket and fill in the blanks.

Woolen, white, mango, ten, sunflowers

- i) I was _____ year old.
- ii) My grandmother sat under the tree _____
- iii) There were _____ in the garden
- iv) The grandmother was knitting _____ scarf.
- v) Grandmother had _____ hair.

Q2. Tick \checkmark the correct answer and cross X the wrong one.

- i) The grandfather sat on the flower bed.
- ii) The boy was ten year old.
- iii) The grandmother was not very old.
- iv) Shed had grey hair.
- v) The boy was interested to see a book with colourful pictures of birds and butter flies.
- vi) The small photograph was in the box.
- vii) The photograph was taken about 40 years ago.
- viii) She used to go swimming in a muddy pool.
- ix) A lemon coloured butterfly settled on the nose of the grandmother.
- x) There was similarity between the photograph and grandmother.

Q3. Match the words with their meaning

Knitting	a plant which requires support to grow.
Wrinkles	jewellery passed on from earlier generations.
Heirlooms	top most room in a house, under the roof.
Attic	process of making woolen clothes using needless
Creeper	folding on skin that happens at old age

Q4. Who said?

- i) My grandmother sat on the string bed.
- ii) Whose picture is it?
- iii) 'A little girl's, of course?
- iv) Grandmother had white hair.
- v) 'yes, I knew her.'

Q5. Correct the spelling of under lined words.

- i) Knitting a woolen scarf requires patience.
- ii) The lady received a beautiful ring which was part of the familys heirlooms.

- iii) The money-plant is a criper which requires support to grow as its stems is weak.
 iv) It was good attempt for keeping me out of mischeaf
 v) Since it was a sunny day, Tapan had to skwint his eyes to look at the ripe mangoes in the tree.

Q6. Write the missing letters and complete the word

- | | |
|-----------------|-------------|
| i) St_in_ | ii) Fa_ed |
| iii) G_rd_n | iv) Wo_le_ |
| v) Kni_t_ng | vi) C_e_per |
| vii) P_otog_ap_ | viii) Fa_ed |
| ix) W_inkl_ | x) S_uin_ed |

Q7. Write meanings in Hindi

Knitting, wrinkle, foggy, clicking, heirloom, faded, creeper, whisper, sleeve, bony

Q8. Answer the following questions in one word

- Write the colour of grandmother's hair?
- Write the name of tree where grandmother was sitting?
- Grandmother was knitting scarf for which month?
- Who was in the photograph?
- Write the name of the flower in garden?

Q9. Answer the following questions

- What was the boy doing after taking his meals?
- How was the photograph?
- Who was in the photograph?
- How can you say that the photograph was colourful?
- Did the boy know who was in the photograph?

Q10. Arrange these words as you find them in dictionary.

Wrinkles, heirlooms, creeper, deterrent, drapery, attic

Assignment-

- Correct the following spellings- Fogi, ettic, drapery, deterrent, streng
- Arrange these words as you find them in the dictionary- sat , string, white, needles, click

Scrap book

- Collect any type of pictures and stick them here.
- Stick the picture of camera and a scene.

Lesson - 23

Where the mind is without fear

Q1. Fill in the blanks

Knowledge, fear, high, broken, fragments, depth

- i) Where the mind is without _____
- ii) The head is held _____ -
- iii) Where _____ is free.
- iv) Where the world has not been _____ up into _____ by narrow domestic walls.
- v) Where words come out from the _____ of truth.

Q2. Write the meanings of given words in Hindi.

Dreary, fear, narrow, depth, desert, aware, domestic, forward, stream, dead habit, haven, freedom, stretch, tire, striving

Q3. Add 's' less and make new words

<p>Word</p> <p>arm</p> <p>wall</p> <p>fragment</p>		<p>_____</p> <p>_____</p> <p>_____</p> <p>_____</p>
<p>fear</p> <p>tire</p> <p>breath</p>		<p>_____</p> <p>_____</p> <p>_____</p>

Q4. Answer the following questions

- i) Who is the poet of the poem 'Where the mind is without fear'?
- ii) Where should the mind be led?
- iii) How can people move towards perfection?
- iv) In what sense is 'Heaven of freedom' used?
- v) What type of freedom helps us to make our country heaven?
- vi) What type of society does the poet dream about?
- vii) What does the poet mean when he says, 'let my country awake'?

Q5. Write four lines of the poem 'Where the mind is without fear'?

Q6. Match the words in column A with opposite words in column B.

A	B	A	B
Ever	Whole	High	Shallow
Fragments	Fold	Narrow	Found
Deep	Cheerful	Stretch	Green
Lost	Hell	Dreary	Low
Desert	Broad	Heaven	never

Q7. Rearrange the given letters

- i) imdn = _____
- ii) rarnow = _____

- iii) ersedt = _____ iv) tpdeh = _____
 v) ide = _____ vi) veer = _____
 vii) rtsmea = _____

Q8. Complete the rhyming words.

- i) Head _____ ii) Tree _____
 iii) Tireless _____ iv) let _____
 v) where _____ vi) clear _____

Q9. Make sentences using following words

knowledge, perfect, high, action, deep, broken up, truth, dreary desert, lost

Q10. Match the words with the given expressions

The mind is without fear	We fill proud
The head is held high	Freedom to express our thinking and ideas
Knowledge is free	With our interest
Broken up into fragments	A society with all types of creed, caste and religious, but not united
Narrow domestic walls	Every one has the right to get the knowledge according to his/her own interest.
Heaven of freedom	Let my country be free
Let my country awake	Request god gift us with us broad thinking and work accordingly.
Tireless striving stretches its arms towards perfection	To be truthful, honest and sincere
Clear stream of reason	Follow bad customs and traditions
Dreary desert sand of dead habit	Think logically
The mind is lead forward by god into ever widening thought and action	Feeling of freedom

Scrap book-

- Collect a few pictures of Rabindranath Tagore and stick it.

Assignment-

- Make some phrases with the help of the given word
Bright, huge, little, beautiful



कक्षा – छठवीं अंग्रेजी

कौशल	माह सितम्बर	माह दिसम्बर	माह मार्च
सुनकर समझकर बोलना	<ul style="list-style-type: none"> कविताओं को हाव-भाव से गा पाता /पाती है। पाठ में आए शब्दों का सही उच्चारण करता /पाती है। पाठ में दिए गए प्रश्नों के उत्तर बोल पाता /पाती है। वार्तालाप में अंग्रेजी शब्दों का प्रयोग करता /पाती है। 	<ul style="list-style-type: none"> पाठ में दिए गए पात्रों के अनुसार Role-play कर पाता /पाती है। कविताओं को सुनकर आनंद उठा पाता है तथा समूह में हाव-भाव के साथ गा पाता /पाती है। कहानी का Dramatization कर सकता/सकती है। वार्तालाप में अंग्रेजी शब्दों का उपयोग काल के अनुसार कर पाता/पाती है। 	<ul style="list-style-type: none"> Instructions को समझकर पालन करता /करती है। अपने साथियों को Instructions दे सकता /सकती है। सुनी या पढ़ी हुई कहानी को अंग्रेजी व हिन्दी भाषा मिलाकर सुना सकता /सकती है। कविता को हाव-भाव के साथ सुना सकता /सकती है एवं समझकर आनंद उठा सकता है। Polite Language का प्रयोग Request करने के लिये कर सकता /सकती है।
पढ़ना पढ़कर समझना	<ul style="list-style-type: none"> Instructions पढ़कर कार्य कर पाता/पाती है। दिए गए पाठ को पढ़ने का प्रयास करता /पाती है तथा शिक्षक की मदद से समझ पाता/पाती है। दो तीन वाक्यों में अंग्रेजी में वार्तालाप करता /पाती है। 	<ul style="list-style-type: none"> चित्रात्मक स्टोरी में दिए गए चित्र को देख एवं पढ़कर संवाद समझ पाता /पाती है। TABLE की सहायता से वाक्य बना पाता /पाती है। 	<ul style="list-style-type: none"> पाठ को पढ़ते समय सही –सही उच्चारण करने का प्रयास करता /करती है। पाठ में आए शब्दों के अर्थ को समझ पाता /पाती है। दिए गए Text को समझ पाता /पाती है।
लिखना	<ul style="list-style-type: none"> पाठ में दिए गए प्रश्नों के उत्तर लिख पाता /पाती है। अनुच्छेद/कहानी/जीवनी को देखकर सही सही लिख पाता/पाती है। सरल शब्दों से वाक्य बना पाता /पाती है। Re-Call कर निबंध एवं पत्र लेखन करता /पाती है। 	<ul style="list-style-type: none"> परिवेशीय वस्तुओं के नाम अंग्रेजी में लिख पाता /पाती है। अपने मन से किसी भी वस्तु पर दो से तीन वाक्य लिख पाता /पाती है। 	<ul style="list-style-type: none"> पाठ में दिए गए प्रश्नों के उत्तर लिख पाता /पाती है। पाठ में दी गई गतिविधियों को समझ कर लिख पाता/पाती है।

टीप – इस सारणी में प्रस्तावित सभी कौशल पाठ्यपुस्तक के हर पाठ के लिए समान रूप से उपयोगी और महत्वपूर्ण है शिक्षक अपनी आवश्यकता और विवेक के अनुरूप इन्हें अध्यापन के दौरान शामिल कर सकते

कक्षा – सातवीं
अंग्रेजी

कौशल	माह सितम्बर	माह दिसम्बर	माह मार्च
सुनकर, समझकर बोलना	<ul style="list-style-type: none"> कविता को सुनकर आनंद उठा पाता / पाती है। पाठ में दिए गए पात्र की सुनकर नकल कर पाता / पाती है। वार्तालाप में अंग्रेजी शब्दों का उपयोग कर / पाती है। अपने सहपाठियों के साथ 2-3 वाक्यों को अंग्रेजी में बोल पाता / पाती है। बोलते समय काल, लिंग का ध्यान रख / पाती है। विभिन्न प्रकार के Instructions/ Requests, direction समझ पाता / पाती है। 		
पढ़ना पढ़कर समझना	<ul style="list-style-type: none"> पाठ में दिए गए पाठों को पढ़ पाता है। तथा Vocabulary समझ पाता / पाती है। कहानी, कविता गद्य को पढ़कर Dramatization कर पाता / पाती है। अपने मित्र या सहपाठी द्वारा लिखे मैसेज को पढ़कर समझ पाता / पाती है। कहानियों को पढ़कर समझ पाता / पाती है। पाठ्यपुस्तक के अतिरिक्त अन्य कहानियों / जीवनी संबंधी किताब को पढ़कर समझ पाता / पाती है। 		
लिखना	<ul style="list-style-type: none"> श्रुत लेख कर पाता / पाती है। किसी विषय पर कल्पना करके अपने मन से लिख पाता / पाती लिखते समय he, she का सही-सही उपयोग कर पाता / पाती है जैसे – लड़की के लिए She, लड़के के लिए He आदि। महापुरुषों की जीवनी / त्यौहारों का वर्णन/अपने मनपसंद खेल के बारे में लिख पाता / पाती है। पाठ में दी गई गतिविधियों को कर पाता / पाती है। पाठ में दिए गए प्रश्नों के उत्तर लिख पाता / पाती है। 		

टीप – इस सारणी में प्रस्तावित सभी कौशल पाठ्यपुस्तक के हर पाठ के लिए समान रूप से उपयोगी और महत्वपूर्ण है शिक्षक अपनी आवश्यकता और विवेक के अनुरूप इन्हें अध्यापन के दौरान शामिल कर सकते हैं।

कक्षा – आठवीं अंग्रेजी

कौशल	माह सितम्बर	माह दिसम्बर	माह मार्च
सुनकर, समझकर बोलना	<ul style="list-style-type: none"> • waters for एवं from a Railway Carriage कविता को हाव-भाव के साथ गा पाता/पाती है। • पाठ में आए Word meaning को बता पाता/पाती है। 	<ul style="list-style-type: none"> • कविता पढ़कर Rhyming Words बोलता /बोलती है जैसे – Mad, Dad आदि। • पाठ में दिए गए प्रश्नों के उत्तर बता पाता/पाती है। • कार्टून देखकर कुछ वाक्य अंग्रेजी में बोल पाता/पाती है। 	<ul style="list-style-type: none"> • दैनिक जीवन में अंग्रेजी के वाक्यों का बोलचाल में उपयोग करता/करती है। • कक्षा में सहपाठी अथवा शिक्षक के साथ वार्तालाप कर पाता/पाती है।
पढ़ना, पढ़कर समझना	<ul style="list-style-type: none"> • पाठ में दिए गए कठिन शब्दों के अर्थ को समझ पाता /पाती है। • चित्र देखकर समझता /समझती है। कहानी, कविता में दी गई क्रियाओं के आधार पर दिए गए चित्रों को क्रमबद्ध रूप से जमा पाता/पाती है। • दिए गए पाठों को शुद्ध उच्चारण के साथ पढ़ पाता/पाती है। • Poem एवं Prose के भाषा के अंतर को समझ पाता /पाती है। • Proverbs की भाषा और साधारण वाक्यों में अंतर समझ पाता /पाती है। • पाठ्यपुस्तक के अतिरिक्त अन्य वाक्यों को भी समझ पाता/पाती है। 		
लिखना	<ul style="list-style-type: none"> • पाठ में दिए गए प्रश्नों के उत्तर एवं गतिविधियों जैसे – वर्ग पहेली, सारणी भरो आदि को कर पाता/पाती है। • वाक्यों की संरचना कर पाता/पाती है। • अंग्रेजी में निबंध, पत्र लेखन कर पाता /पाती है। • अपने परिवेश की वस्तुओं के नाम अंग्रेजी में लिख पाता/पाती है। 		

टीप – अंग्रेजी विषय में पूरे पाठों में यही प्रक्रिया लागू होगी किन्तु संदर्भों के अनुसार इसमें परिवर्तन होगा। जैसे – सितम्बर माह में 1 से 8 तक के पाठों में उक्त कौशलों का विकास होगा तो दिसम्बर तक उसके आगे के पाठ 8 से 16 तक इन्हीं कौशलों का विकास होगा